

U.S.SAWS™

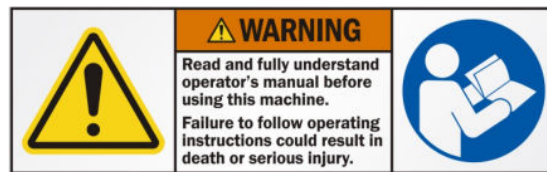

U.S.SAWS VALVE EXERCISER OPERATING MANUAL

Notice of Copyright Protection

Copyright 2020, by U.S.SAWS . All rights reserved. This work may not be reproduced or disseminated in whole or in part by any means without the prior written permission of U.S.SAWS

11-3-2022

U.S.SAWS™

**WATERWORKS
DIVISION**

P: 866-987-7297 F: 813-621-7125
Visit us at www.ussaws.com
sales@ussaws.com



INTRODUCTION & SPECIFICATIONS

1.0 INSTRUCTIONS FOR USE OF MANUAL SECTIONS

Section	Page
Table of Contents & Introduction	2
Symbols & Decals	3
Safety Instruction	4 - 5
Operation	6 - 10
Parts Breakdown.....	11 - 13
Maintenance & Inspection	14
Related Products & Accessories	15
Warranty & Service	16 - 17

Foreword/Introduction

This manual outlines the maintenance and operation of the Valve Exerciser. This is a professional tool and is intended for use by trained and experienced operators. To get maximum benefit from your tool and to ensure maximum safety, be sure to read this manual thoroughly. You should also periodically review safety instructions. Keep all manuals provided with your equipment in a safe place at all times.

The information and specifications included in this publication were in effect at the time of approval for printing. U.S.SAWS reserves the right, however, to discontinue or change specifications or design at any time without notice and without incurring any obligation.

Valve manufacturers suggest that valves should be exercised through a full cycle (open to closed to open) and returned to its normal position on a regular schedule. This is done to help prevent build-up and other deposits that could interfere with normal use or prevent a tight shut-off. Valve exercising has the potential to save thousands of dollars in emergency repairs by helping to keep all valves operational and identifying problems and repair needs on a non emergency basis.

U.S.SAWS Valve Exerciser (VEX400) is a battery-operated, portable, and powerful valve exercising machine and the most versatile and complete unit available to-date. It has variable torque settings ranging up to 400 ft-lbs. The portability, power, battery operated-feature, and easy-to-use design of our Valve Exerciser are the top reasons customers prefer the VEX400 from other valve exercisers.

Read this entire operations and maintenance manual before using your new tool. Pay close attention to the Rules for safer operation,

Disclosure

By purchasing and using the Valve Exerciser, you agree to release U.S.SAWS of any and all liability. Under no circumstances will U.S.SAWS be held liable for incidental or consequential damages resulting from the use of this product and/or defective parts or products associated with this product.

- It is the responsibility of the owner/user to ensure that the operating instructions have been read and understood by the operator before the operation of the equipment begins.
- It is the responsibility of the owner/user to understand and perform the maintenance and storage procedures as explained in the operating instructions.

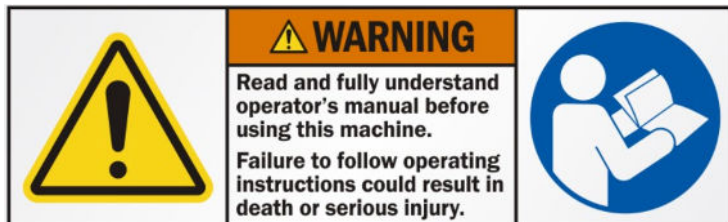

ONLY OPERATE VEX400 WITH DRILL IN SPEED POSITION 1

This tool creates an enormous amount of force. Beware of crushing your fingers or other body parts.



2.0 SPECIFICATIONS

Model	Valve Exerciser Deluxe Package
Part Number	US75005
Weight	80
Dimensions	5' x 2' x 1'
Minimum Depth	8"
Maximum Depth	36" (108" with extensions)
Power Requirement	18V Batteries Supplied

Model	Treatment Plant Kit
Part Number	US75060
Height Range	3ft - 5ft
Weight	30 lbs



SYMBOLS & DECALS

3.0 SYMBOLS & DECALS

For Safe Operation

You must be qualified for safe operation of the U.S.SAWS Valve Exerciser machine. You must clearly understand the written instructions supplied by U.S.SAWS, be trained - including actual operation - & know the safety rules & regulations for the job site. It is a safety practice to point out & explain safety signs & practices to others & to make sure they understand the importance of following these instructions.

Be Safe

Human error is the result of many factors: carelessness, fatigue, sensory overload, preoccupation, unfamiliarity with the machine or attachments, or drugs or alcohol, to name a few. You can avoid serious injury or death caused by these & other unsafe work practices. Be safe and never assume accidents cannot happen to you.

For your safety and the safety of others, act safely and encourage your fellow workers to act safely as well.



Read and understand operator's manual before using this machine. Failure to follow operating Instructions could result in injury or damage to equipment.

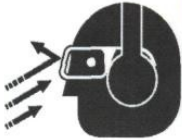

Always wear protective glasses or full face protection



Wear Head Protection, breathing protection, and the use of hearing protection is mandatory



Wear safety boots when operating this machine



Wear appropriate clothing



Wear hand protection



Wear proper electrostatic grounding equipment at all times.



Wear proper electrostatic grounding equipment at all times.

Dangers, Warnings and Cautions.

The purpose of safety symbols and explanations are to attract your attention to possible hazards and how to avoid them. The safety symbols and explanations do not by themselves eliminate any danger. The instructions or warnings they give are not substitutes for proper accident prevention measures.



DANGER: Indicates an imminently hazardous situation that if not avoided, will result in death or serious injury. This signal word is limited to the most extreme situations.



WARNING: Indicates a potentially hazardous situation that, if not avoided, could result in death or serious injury.



CAUTION: Indicates a potentially hazardous situation that, if not avoided may result in minor or moderate injury. It may also be used to alert against unsafe practices that may cause property damage.



SAFETY INSTRUCTIONS

4.0 SAFETY INSTRUCTIONS

4.1 KNOW THE RULES & YOUR EQUIPMENT.

Most job sites have rules governing equipment use & maintenance. Before starting at a new work location, check with the supervisor or safety coordinator. Ask about any rules or regulations you need to abide.

OSHA enforces federal laws within the United States that apply to the safe operation, application, & maintenance of equipment on job sites. It is the employer's responsibility to comply with these laws.

Do not operate this machine unless you have read the operations and maintenance manual carefully.

4.2 RECEIVE PROPER TRAINING.

Do not operate this machine unless you have received operational and maintenance training from a U.S. SAWS representative or from an authorized distributor for U.S.SAWS.

4.3 PROTECT YOUR FEET.

Observe all applicable local, state and federal safety regulations. Wear OSHA approved foot protection.

4.4 PROTECT YOUR EYES.

Observe all applicable local, state and federal safety regulations. Wear OSHA approved safety glasses.

4.5 PROTECT YOUR HEARING.

Observe all applicable local, state and federal safety regulations. Wear OSHA approved hearing protection.

4.6 DRESS PROPERLY.

Do not wear loose clothing or jewelry that can be caught in moving parts. Wear protective hair covering to contain long hair. Keep hair away from motor air vent. Rubber gloves and non-skid footwear are recommended when working outdoors.

4.7 AVOID A DANGEROUS ENVIRONMENT.

Do not expose machine to rain. Do not use machine in wet conditions. Water entering a power tool will increase the risk of electric shock. Keep work area well lit. When working at an elevated location, pay attention to articles and persons below. If operating the power tool in damp locations is unavoidable, use a Ground Fault Circuit Interrupter (GFCI) protected supply. Use of an GFCI reduce the risk of electric shock.

4.8 AVOID ANY AREAS OR ACTIONS THAT EXPOSE YOU TO CARBON MONOXIDE.

Exhaust gas from gasoline engines contains dangerous carbon monoxide. Breathing it can cause unconsciousness and even kill you. Always operate gasoline engine machines in a well-ventilated area. Do not operate in areas where exhaust fumes could accumulate without wearing appropriate respiratory protection. Consult your employer and OSHA regarding use of appropriate respirator for dangerous carbon monoxide gases.

4.9 KEEP WORK AREA CLEAN. DO NOT RUN OVER ANYTHING.

Loose objects could be thrown from crack. Make sure area to be cut is clear from people and any loose objects, nuts, bolts, etc. Never run over any loose objects.

4.10 KEEP CHILDREN AND VISITORS AWAY.

Do not allow anyone to stand in line with the blade path. Do not let children or visitors contact machine or extension cord. Keep children and visitors away from the work area.

4.11 KEEP FIRM GRIP ON MACHINE.

During normal operation as instructed in Section 6.0, keep a firm hold on the handle grips and maintain control of the machine until the blade completely stops.

4.12 SHUT OFF MACHINE.

When not in use, before servicing and when changing accessories shut off engine. Release the lever switch and move the on/off switch to the OFF position. Move the fuel valve lever to the OFF position.

4.13 STORE IDLE EQUIPMENT.

The machine and tools should be stored in a dry and secure location when not in use. Keep equipment out of reach of children.

4.14 OBTAIN SAFETY DATA SHEET (SDS) FOR ALL WORK SURFACE MATERIALS.

This includes primers, all coatings, adhesives, tile and crack filling materials, etc. Do not attempt to cut, clean out or remove material without SDS information. Consult SDS sheet for hazards information. Be aware that some materials are explosive as a dust.

4.15 DO NOT OVERREACH.

Keep proper footing and balance at all times.

4.16 MAINTAIN MACHINE WITH CARE.

Keep machine clean and follow maintenance procedures for better and safer performance. Keep handles dry, clean, and free from oil and grease. Follow instructions for lubricating and changing accessories.

4.17 REMOVE ADJUSTING TOOLS.

Form a habit of checking to see that tools such as adjusting wrenches are removed from the machine and properly stored before starting the engine.

4.18 STAY ALERT.

Watch what you are doing. Use common sense. Do not operate machine when you are tired or fatigued.

4.19 DO NOT USE DRUGS, ALCOHOL, MEDICATION.

Do not operate machine while under the influence of drugs, alcohol, or any medication.

4.20 KEEP THE RIGHT PARTS IN THE RIGHT POSITIONS.

Do not operate machine with parts missing or improperly mounted.

4.21 CHECK DAMAGED PARTS.

Verify all machine guards are in good condition and will function properly before using the machine. Check for alignment of moving parts, binding of moving parts, breakage of parts, mounting, and any other conditions that may affect machine operation. A guard, power switch or other part that is damaged should be properly repaired or replaced by an authorized service center unless indicated elsewhere in this instruction manual. Do not operate machine if lever or engine on/off switch does not function properly.



SAFETY INSTRUCTIONS

4.22 SECURELY MOUNT ACCESSORIES TO THE MACHINE.

Extra care must be taken an elevated location to prevent injury to someone on a lower level in the event the tool or accessory should drop. Do not operate without fall protection for operator and debris protection for public.

4.23 NEVER TOUCH THE MOVING PARTS.

Never touch moving parts such as shaft and drill extensions.

4.24 STOP OPERATION IMMEDIATELY IF ANY ABNORMALITY IS DETECTED.

Stop using machine immediately if any abnormalities are observed during operation. Examples of abnormalities include unusual noise and vibration.

4.25 WHEN REPLACING A PART, USE THE SAME TYPE AND QUALITY.

When replacing a component part with a new one, use only the same type and quality of new part. Never attempt to repair a machine if you are unfamiliar with proper procedures and techniques required.

4.26 LOAD AND UNLOAD SAFELY.

Use proper heavy lifting procedures. Read & understand manuals before loading & unloading.

4.27 SAVE THESE INSTRUCTIONS.

Refer to this operations and maintenance manual as well as any additional instructions included from other manufacturers and organizations.

4.28 REFER TO METABO MANUAL

Refer to Metabo 18v 5.2ah Li-ion Battery Pack Owner's Manual included with your VEX kit for operations, maintenance and safety guidelines.

ONLY OPERATE VEX400 WITH DRILL IN SPEED POSITION 1

This tool creates an enormous amount of force. Beware of crushing your fingers or other body parts.



DUST WARNING

Cutting, especially when DRY cutting, generates dust that comes from the material being cut, which frequently contains silica.

Silica is a basic component of sand, quartz, brick clay, granite and numerous other minerals and rocks. Exposure to excessive amount of such dust can cause:

- Respiratory diseases (affecting your ability to breath), including chronic bronchitis, silicosis and pulmonary fibrosis from exposure to silica. These diseases may be fatal;
 - Skin irritation and rash; and
 - Cancer according to NTP* and IARC*
- * National Toxicology Program, International Agency for Research on Cancer

Take precautionary steps

- Avoid inhalation of and skin contact with dust, mist and fumes;
- Wet cut when feasible, to minimize dust;
- Wear and ensure that all bystanders wear appropriate respiratory protection such as dust masks designed to filter out microscopic particles. (See OSHA 29 CFR Part 1910.1200)

California Prop 65 Warning: Use of this product can cause exposure to materials known to the State of California to cause cancer and/or birth defects or other reproductive harm.

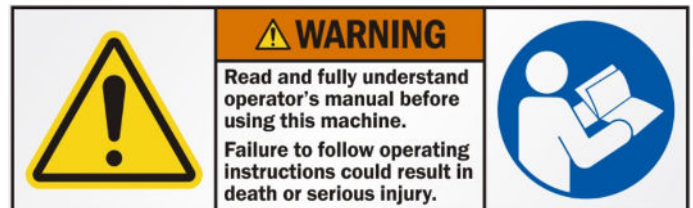

OPERATION

5.0 U.S.SAWS Valve Exerciser (VEX400) is a battery-operated, portable, and powerful valve exercising machine and the most versatile and complete unit available to-date. It has variable torque settings ranging up to 400 ft-lbs. The portability, power, battery operated-feature, and easy-to-use design of our Valve Exerciser are the top reasons customers prefer the VEX400 from other valve exercisers.

5.1 Power Head in Storage Case

Battery (3 with Machine)

Hex Shear Pin (2 Spares)



Twist Lock Extension

Battery Charger

5.2 Package Contains:

Deluxe Package Includes: (PN: US75005)

- Power Head & Carry Case
- Deluxe Drive Shaft with Valve Key/Socket
- Hard Storage Case for Drill
- Storage Bag for Legs & Extensions
- (3) Shaft Extensions: (1) 1ft, (1) 2ft, (1) 3ft
- (3) 18V Batteries & Charge

Deluxe Drive Shaft for Valves Up to 9'-0" Deep

Hydrant Package Includes: (PN: US75001)

- Power Head & Carry Case
- Padded Torque Handle
- Hydrant Pentagon Key/Socket
- (2) 20V Batteries & Charger
- (1) Leg with (1) Foot Platform

Items Can Be Added to Valve Exerciser Package



Digital Counter



Hydrant Key Available



Battery Powered



Torque Dial



Unit with All Extensions Added

Depth with Extensions

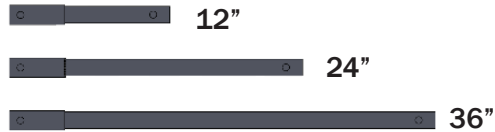

Legs Can Be Used Horizontally

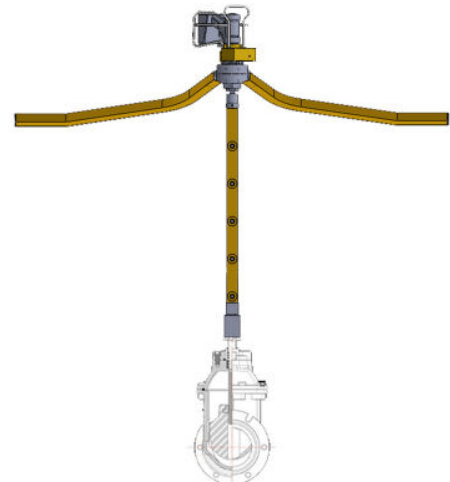

OPERATION

5.3 Remove valve cover.



5.4 Put the drive shaft onto the valve nut. The shaft should extend 16"-24" above grade to engage with the drive shaft.



5.5 Install solid extension onto gearbox output.



5.6 Engage twist lock mechanism to lock solid extension in place



5.7 Attach power head unit to drive shaft.



5.8 Start drill in torque output 1-4 as to not overload the valve.



5.9 Operating the valve. Use caution when cycling valve. Use slower speeds when the valve size is not known or when approaching the open or closed position.



5.10 If valve does not move, increase the torque setting incrementally. To help gauge the tension required and evaluate the condition of the valve.



OPERATION

5.11 Torque ratings at each drill position

Position 1-4

75 -125 ft/lb

Recommended for use with one operator

Pos	ft/lb
1	75
2	95
3	110
4	125

Position 5-7

135-165 ft/lb

Recommended for use with two operators

Pos	ft/lb
5	135
6	150
7	165

Position 8-10

200-260 ft/lb

Recommended for use with two operators and leg(s) mounted horizontally

Pos	ft/lb
8	200
9	230
10	260
Lock	Peak
	400

*The no clutch option creates up to 400 ft/lbs of torque and should be used with discretion. Use only in short bursts as it could cause damage and serious injury.

5.12 Open/Close Turns per Valve Size

American

2"	2.5"	3"	4"	6"	8"	10"	12"	14"	16"	18"	20"	24"	30"	36"	42"	48"	54"	60"	66"
9	11	13	14	20	26	32	38	44	50	56	62	76	379	448	694	789	789	984	984

Mueller - Resilient Wedge Gate Valves

2"	2.5"	3"	4"	6"	8"	10"	12"	14"	16"	18"	20"	24"	30"	36"	42"	48"
8	11	11	14	20.5	26.5	33	38.5	43.5	49	57	63	75	372	444	516	588

Mueller - Double Disc Gate Valves

2"	2.5"	3"	4"	6"	8"	10"	12"	14"	16"	18"	20"	24"	30"	36"
5.5	6.25	7.5	14.5	20.5	27	33.5	38.5	46	53	59	65	77	260	312

*These are just for reference and are based on specific valve brands. Please consult your valve manufacturer for specific valve information



OPERATION

5.13 Power Head Breakdown

U.S.SAWS has designed the 9" solid extension with a few degrees of movement to aid in a quick and easy set up. However, exceeding the normal amount of alignment variables causes binding and stress that can damage the extension and interlocking components.



In cases of uneven or downhill slopes, approach exercising from the downhill side. This allows the operator a safer standing position and makes it easier to set the tool for operation.

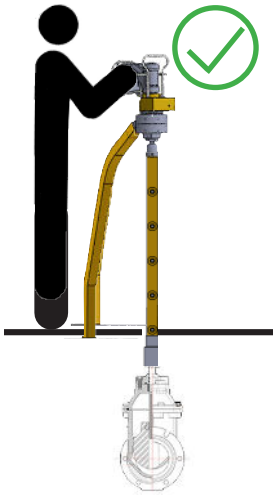

- Platform should be flat on the ground and legs should be shoulder width apart.
- Drill and drive shaft should be in a level line perpendicular to the ground.
- Be sure to lock the sliding collar to prevent slippage.

Tip:

Before inserting 9" solid extension down into the drive shaft set the tool up just to the side of the valve box, this way you can see if any of the alignment variable are out of place.

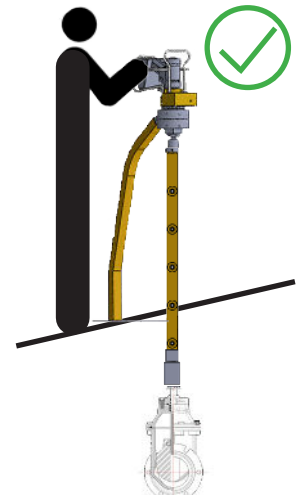

Do not lean the unit forwards or backwards against the drive shaft. Improper alignment will cause binding and stress internal components of the gearbox. Evidence of such damage is considered misuse and will void the warranty.

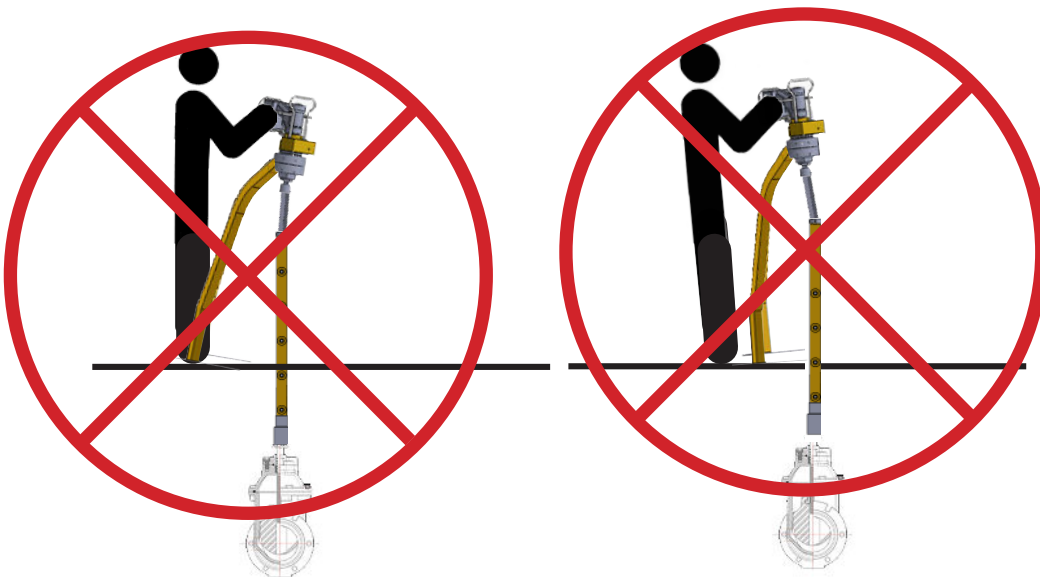

OPERATION

5.14 Operating the Twist Lock

5.15 INSTALL

5.15.1 Turn the lock mechanism counter clockwise to return the retaining pin to the recess.

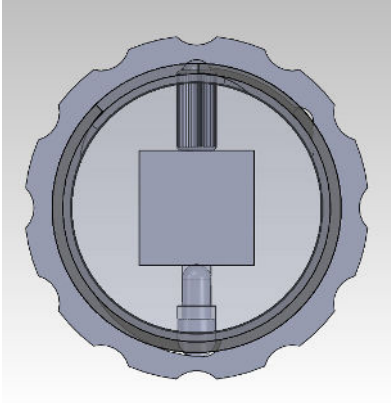

5.15.2 Then place the solid extension onto the output of the gearbox

5.15.3 Turn the lock mechanism clock wise to engage the retaining pin in the recess of the out put shaft. This will secure the solid extension to the gearbox.

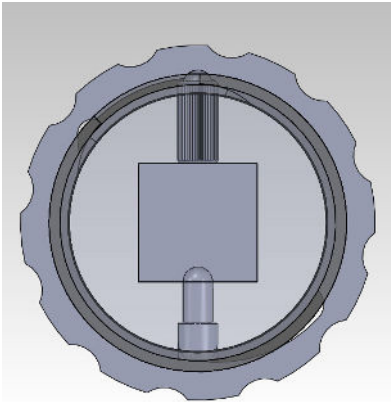

5.15 REMOVAL

5.15.1 Turn the lock mechanism counter clockwise to release the retaining pin and remove the solid extension.

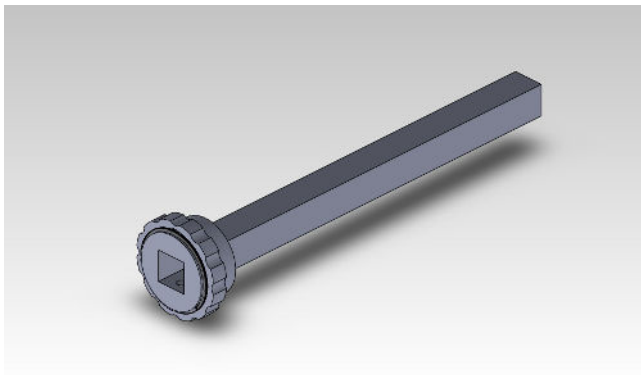

PARTS BREAKDOWN

6.0 Power Head Breakdown

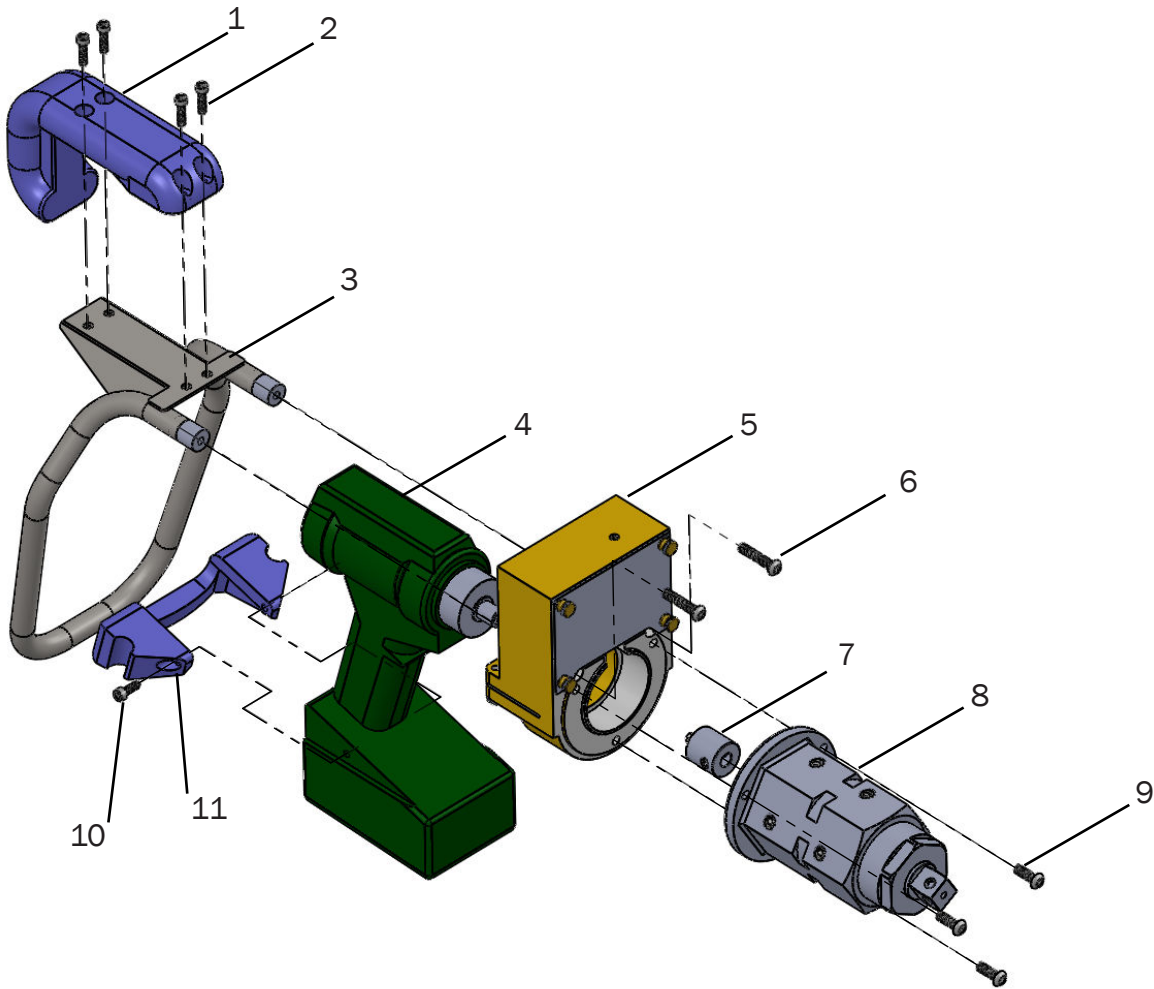

Number	Part Number	Description
1	US75025-6	Upper Roll Cage Bumper
2	US31126-75	Socket Head Cap Screw (Qty 4)
3	US75028	Roll Cage
4	SXBS18LTXIMPULS	Metabo BS18 LTX Drill
5	US75011	Counter Housing Assembly
6	US60115	Screw (Qty 2)
7	US75012	Magnet Holder Assembly
8	US75013	Gearbox Hex Assembly
9	US60223	Screw (Qty 3)
10	US60224	Screw (Qty 2)
11	US75025-7	Lower Roll Cage Bumper



PARTS BREAKDOWN

6.1 Legs Breakdown

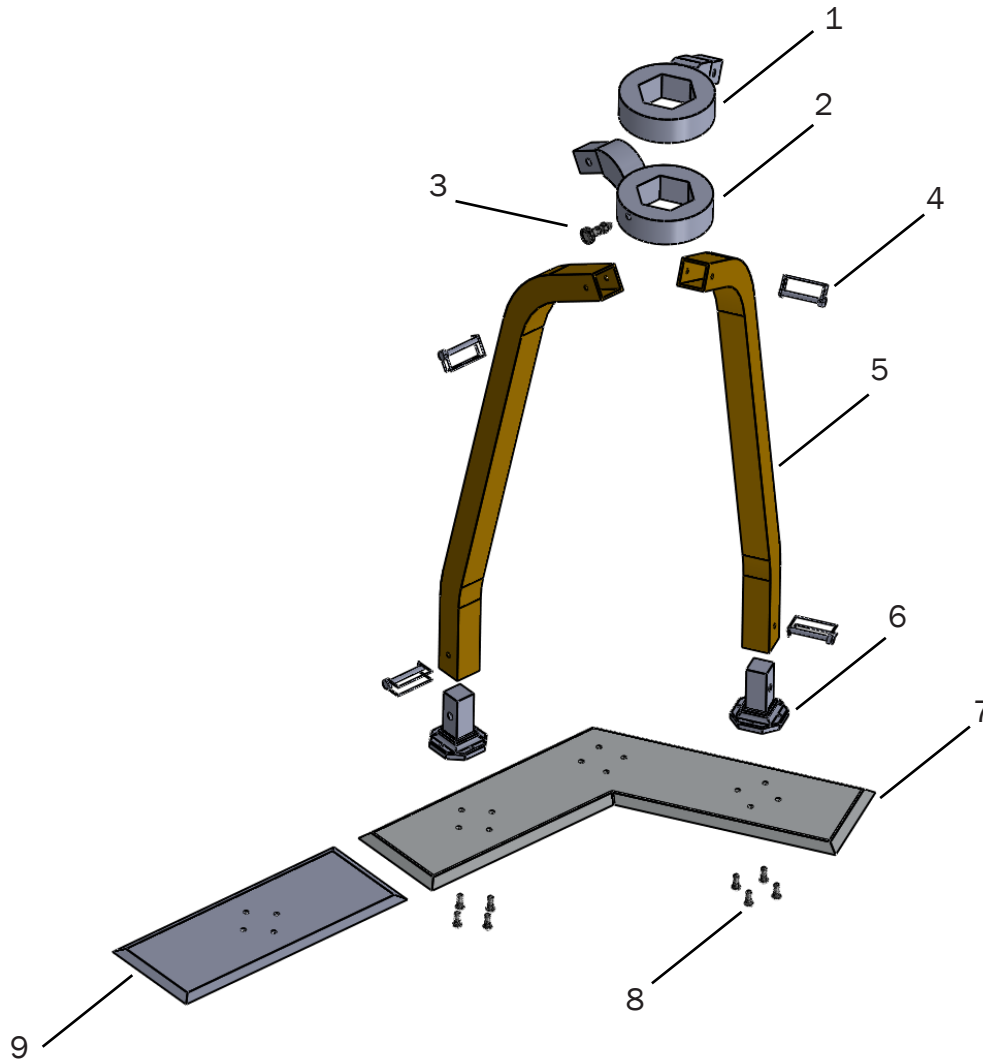

Number	Part Number	Description
1	US75016-2	Upper Leg Hex
2	US75016-3	Lower Leg Hex
3	US28191-8	Locking Pin For Lower Leg Hex
4	US31077-1	Safety Hitch Pin (Qty 4)
5	US75016-1	Leg (Qty 2)
6	US75021-1	Leg Mounting Tower (Qty 2)
7	US75040	"V" Foot Plate
8	US75020	Rectangular Foot Plate
9	US60223	1/4 - 20 x 3/4" Button Head Socket Screw (Qty 8)



PARTS BREAKDOWN

6.2 Extension Breakdown

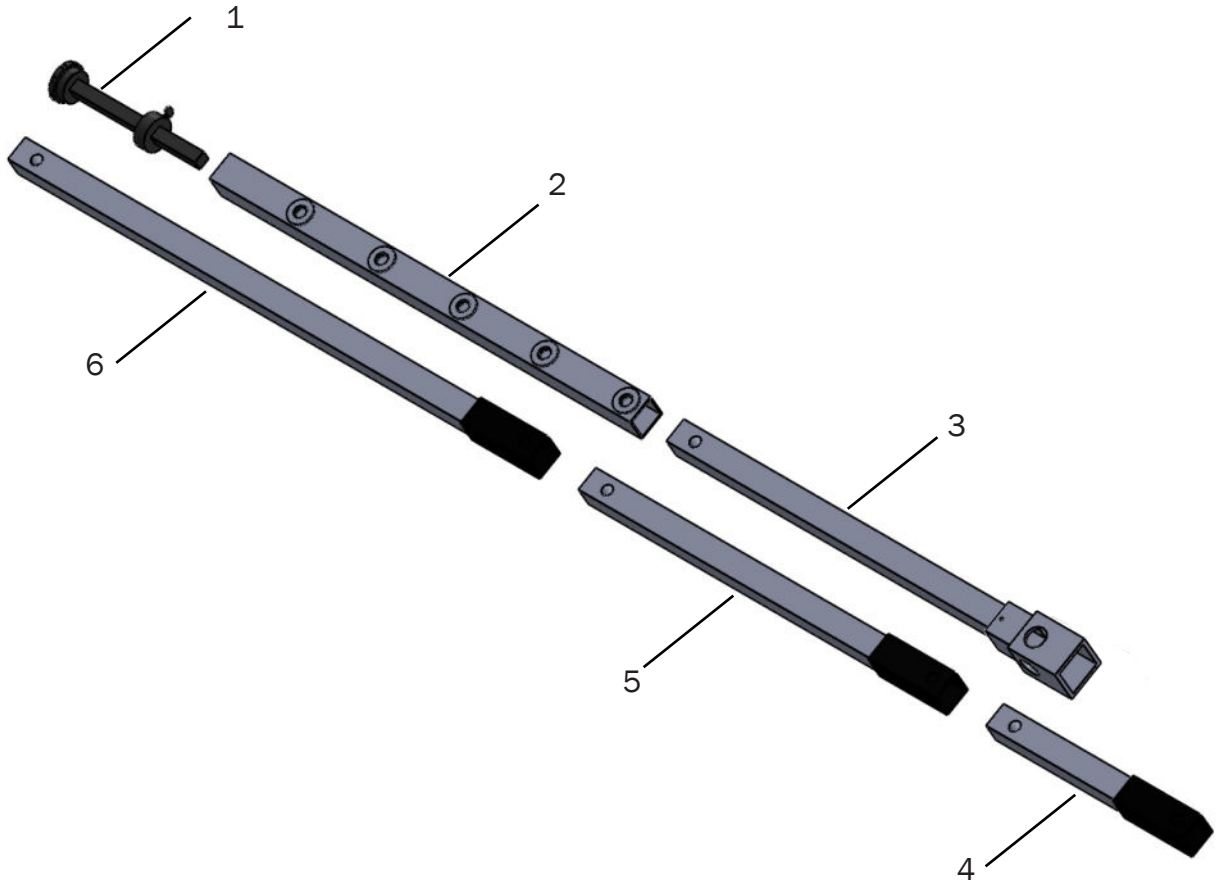

Number	Part Number	Description
1	US75033	Solid Extension with Twist Lock
2	US75031-3	Drive Shaft - Deluxe - Female
3	US75031-7	Drive Shaft - Deluxe - Male
4	US75031-4	12" Extension
5	US75031-5	24" Extension
6	US75031-6	36" Extension

*Not Pictured

US75012-1	Hex Shear Key (with two spares)
US60403	Storage Bag
US75050	Hard Case
SXB625592	18v Metabo Battery (Qty 3)
SXB627046	18v Metabo Battery Charger

13



MAINTENANCE AND INSPECTION

7.0 MAINTENANCE AND INSPECTION

7.1 GEARBOX REPAIR

7.1.1 Remove allen screws to access gearbox.



7.1.2 Remove gearbox.

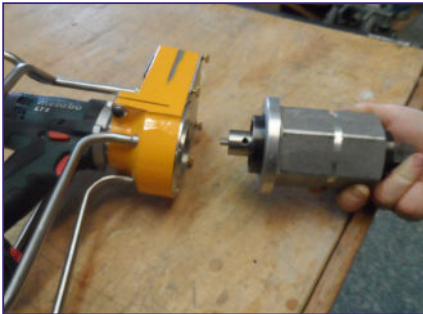

7.1.3 Remove damaged shear pin.



7.1.4 Replace shear pin and reassemble power head unit.



7.2 CHANGING THE BATTERY IN THE COUNTER

7.2.1 Remove the four screws on the under side of the counter that are holding the cover on.

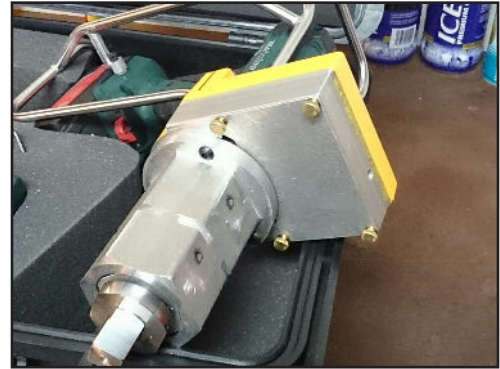

7.2.2 Remove the cover and remove both 9v batteries.

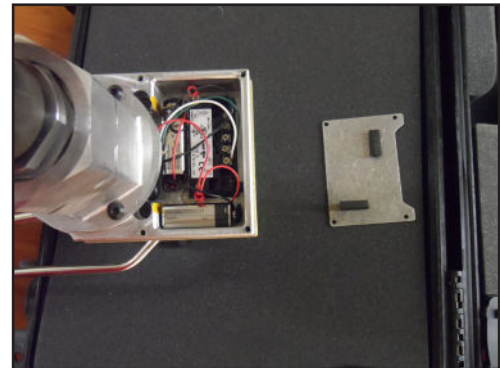

7.2.3 Replace both 9v batteries. Replace cover and screws.

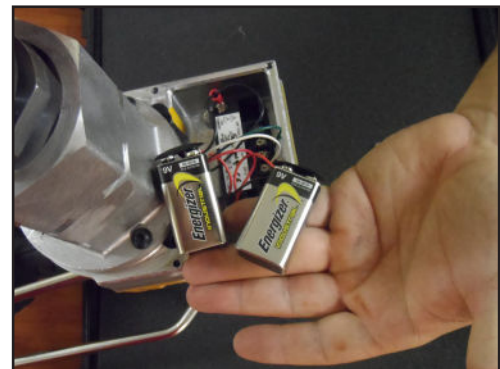

RELATED PRODUCTS & ACCESSORIES

8.0 RELATED PRODUCTS & ACCESSORIES

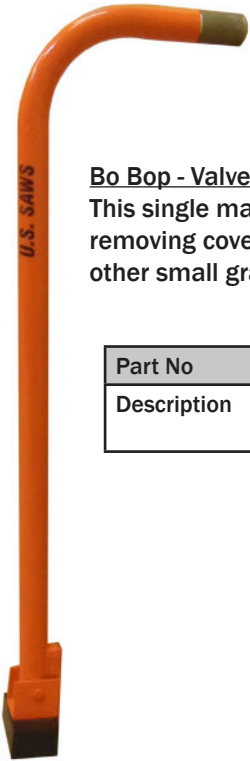

Bo Bop - Valve Box Lifter

This single magnet cover lifting model is great for removing covers of water valves, electrical plates, and other small grates. The Bo Bop can lift over of 25 lbs.

Part No	US30298
Description	Single Magnet Valve Box Cover Lifter with Hammer Attachment

Hydrant Key

This easy-to-use part fits all types of hydrant pentagon nuts and its unique design allows for quick adjustment and a perfect fit.



Part No	US75611
Description	Attachment for exercising Hydrants

OS&Y Valve Adapter

Outside Stem & Yoke Valve Adapter is designed to allow exercising of post indicator and wheel valves. Includes 1ft shaft extension.

*Call for more information



Part No	US75608
Description	OS&Y Adapter Hub

Part No	US75609
Description	OS&Y Adapter Drive Socket with twist lock

Power Inverter

A Power Inverter can be used in conjunction with your vehicle to charge the batteries when not in use.



Part No	SX20023
Description	1200W Pure Sine Wave Inverter



WARRANTY AND SERVICE

9.0 WARRANTY AND SERVICE

9.1.1 Warranty

This document is to be used as a guide in determining warranty policies and procedures for U.S.SAWS and its U.S.SAWS products. It is to be used in determining whether a warranty is justified and as a procedural guide in completing a U.S.SAWS warranty claim form.

9.1.2 Warranty Responsibility

The distributor or the end user must prepare a Machine Warranty Information Card when the machine is delivered. Failure to comply will make any and all warranties on this equipment null and void. Credit for warranty repairs will be given only after receipt of the WARRANTY CLAIM FORM, properly completed with all the required details. Submittal details are described later in this document.

9.1.3 Warranty Policy

9.1.3.1 U.S.SAWS warrants its U.S.SAWS products against defects in material and workmanship under normal and proper use for a period of one year (365) days from the date of delivery; in the case of Rental Fleet Machines, date of assignment to Rental Fleet. Such warranty is extended only to the buyer who purchases the equipment directly from U.S.SAWS or its authorized distributor. This warranty does not include expendable parts such as, but not limited to, plugs, cutters, blades, blast wheel, wear parts, liners and seals.

9.1.3.2 The obligation under this warranty is strictly limited to the replacement or repair, at US SAWS's option, of machines and does not include the cost of transportation, loss of operating time, or normal maintenance services.

9.1.3.3 This warranty does not apply to failure occurring as a result of abuse, misuse, negligence, corrosion, erosion, normal wear and tear, alterations or modifications made to the machine without express written consent of U.S.SAWS .

9.1.3.4 Warranty request must be submitted in writing within thirty (30) days after failure.

9.1.3.5 Written authorization to return merchandise under warranty must first be obtained from U.S.SAWS .

9.1.3.6 U.S.SAWS reserves the right to inspect and make the final decision on any merchandise returned under warranty.

9.1.3.7 U.S.SAWS offers no warranty with respect to accessories, including but not limited to, engines, motors, batteries, electrical boards, tires and any other parts not manufactured by us but which the original manufacturer warrants.

9.1.3.8 U.S.SAWS reserves the right to make product changes or improvements without prior notice and without imposing any obligation upon itself to install the same on its products previously sold.

9.1.3.9 The above warranty conditions can only be altered by US SAWS. US SAWS must confirm alterations in writing for each specific transaction.

9.1.3.10 U.S.SAWS reserves the right to establish specific warranty terms for used or demo machines on an individual transaction basis. Invoices covering such merchandise will clearly state the provisions of the applicable warranty for each specific transaction.

9.1.3.11 WE DO NOT AUTHORIZE ANY PERSON, REPRESENTATIVE OR SERVICE OR SALES ORGANIZATION TO MAKE ANY OTHER WARRANTY OR TO ASSUME FOR US ANY LIABILITY IN CONNECTION WITH THE SALE OF OUR PRODUCTS OTHER THAN THOSE CONTAINED HEREIN.

9.1.3.12 UNDER NO CIRCUMSTANCES SHALL US SAWS BE LIABLE TO CUSTOMER OR ANY OTHER PERSON FOR ANY DIRECT, INCIDENTAL, OR CONSEQUENTIAL DAMAGES RESULTING FROM THE USE OF THE PRODUCT OR ARISING OUT OF ANY BREACH OF ANY WARRANTY OR FOR ANY SPECIAL OR CONSEQUENTIAL DAMAGES OF ANY CHARACTER, INCLUDING WITHOUT LIMITATIONS, DAMAGES FOR ANY LOSS OF GOODWILL, WORK STOPPAGE, OR ANY AND ALL OTHER COMMERCIAL DAMAGES OR LOSSES.

9.1.3.13 U.S.SAWS MAKES NO OTHER WARRANTIES, EXPRESSED OR IMPLIED, INCLUDING, BUT NOT LIMITED TO, THE IMPLIED WARRANTIES OF MERCHANTABILITY AND FITNESS FOR A PARTICULAR PURPOSE WITH RESPECT TO THE US SAWS PRODUCTS SOLD PURSUANT THERETO.



MACHINE WARRANTY INFORMATION CARD

TO ENSURE THE PROPER WARRANTY COVERAGE IS EXTENDED TO THE OWNER OF THIS MACHINE, FILL OUT THE ATTACHED CARD COMPLETELY AND ACCURATELY.

WARRANTY REGISTRATION CARD

IMPORTANT! To ensure that your U.S.SAWS machine is covered under warranty, please fill in the following information and mail or fax it to U.S.SAWS, 8004B E. Broadway Ave. Tampa, FL 33619, Fax No. (813) 621-7125

COMPANY
NAME
ADDRESS
INTENDED USE
DATE OF PURCHASE
INTENDED USE
SERIAL NUMBER

If you are not the owner of record as shown on the manual copy of the warranty registration card, do not operate this machine before contacting U.S.SAWS at (866) 987-7297. Verify the following before operating the equipment:

CHANGE OF OWNER OR NEW ADDRESS REGISTRATION CARD

IMPORTANT! To ensure that your U.S.SAWS machine is covered under warranty, please fill in the following information and mail or fax it to U.S. SAWS, 8004B E. Broadway Ave. Tampa, FL 33619, Fax No. (813) 621-7125

COMPANY
NAME
ADDRESS
INTENDED USE
DATE OF PURCHASE
INTENDED USE
SERIAL NUMBER

17

