

U.S.SAWS™



U.S.SAWS 7" GRINDER OPERATING MANUAL

	<p>WARNING</p> <p>Read and fully understand operator's manual before using this machine.</p> <p>Failure to follow operating instructions could result in death or serious injury.</p>	
--	--	--

Notice of Copyright Protection

Copyright 2020, by U.S.SAWS . All rights reserved. This work may not be reproduced or disseminated in whole or in part by any means without the prior written permission of U.S.SAWS

02-05-2021

U.S.SAWS™

**SURFACE PREP
DIVISION**

P: 877-817- 6687 F: 813-621-7125
Visit us at www.ussaws.com
sales@ussaws.com



INTRODUCTION & SPECIFICATIONS

1.0 INSTRUCTIONS FOR USE OF MANUAL SECTIONS

Section	Page
Table of Contents & Introduction	2
Symbols & Decals	3
Safety Instruction	4 - 5
Safety & Operation	6
Parts Breakdown	7
Recommended Cup Wheels	8
Warranty & Service	9 - 10

Foreword/Introduction

The owner's manual is intended to point out some of the basic safety situations that may be encountered during the normal operation & maintenance of the 7" Grinder & to instruct you in safety practices for dealing with these conditions. Keep all manuals provided with your machine in a safe place at all times.

The information and specifications included in this publication were in effect at the time of approval for printing. However, U.S.SAWS reserves the right to discontinue or change specifications or design at any time without notice and without incurring any obligation.

The U.S.SAWS 7" Grinder was designed for concrete floor grinding and polishing concrete surfaces near walls and other vertical surfaces. This grinder can be used indoors or outdoors in small or large spaces. The grinder utilizes 7" diamond cup wheel to level, smooth, or clean the edges of the concrete slab. The U.S.SAWS 7" grinder features the U.S.SAWS Generation 2 concrete dust shroud system for a clean, dust-free work environment.

Dangers, Warnings and Cautions.

The purpose of safety symbols and explanations is to attract your attention to possible hazards and how to avoid them. The safety symbols and explanations do not by themselves eliminate any danger. The instructions or warnings they give are not substitutes for proper accident prevention measures.



DANGER: Indicates an imminently hazardous situation that, if not avoided, will result in death or serious injury. This signal word is limited to the most extreme situations.



WARNING: Indicates a potentially hazardous situation that, if not avoided, could result in death or severe injury.



CAUTION: Indicates a potentially hazardous situation that, if not avoided, may result in minor or moderate injury. It may also be used to alert against unsafe practices that may cause property damage.

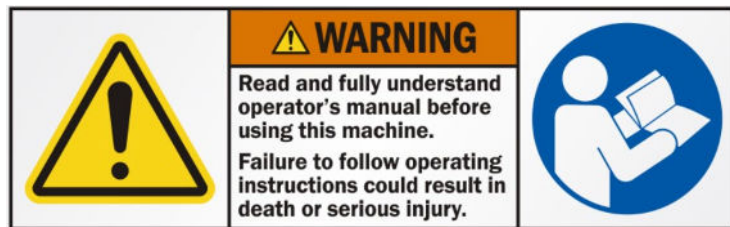

Model Identification: Record machine serial number plate information below for future reference

2.0 SPECIFICATIONS

Size	7"	
Part Number w/ Convertible Shroud	SX60006CG2 SX60006PPG2	SX60010CG2
Production Capacity (sq ft/hr)**	150-200	150-200
Grinder Model	Metabo W24-230	Metabo W24-180
Power Source	15 amp Electric	15 amp Electric
RPM	6,600	8,500
Power Requirements	120V, 60Hz	120V, 60Hz
Wheel Diameter	7"	7"
Weight	28 lb	16 lb



SYMBOLS & DECALS

3.0 SYMBOLS & DECALS

For Safe Operation

You must be qualified for safe operation of the U.S.SAWS 7" Grinder. You must clearly understand the written instructions supplied by U.S.SAWS, be trained - including actual operation - & know the safety rules & regulations for the job site. It is a safe practice to point out & explain safety signs & procedures to others & to make sure they understand the importance of following these instructions.

Be Safe

Human error results from many factors: carelessness, fatigue, sensory overload, preoccupation, unfamiliarity with the machine or attachments, or drugs or alcohol, to name a few. You can avoid serious injury or death caused by these & other unsafe work practices. Be safe and never assume accidents cannot happen to you.

For your safety and the safety of others, act safely and encourage your fellow workers to operate safely as well.



Wear appropriate clothing



Wear hand protection



Wear proper electrostatic grounding equipment at all times.



Read and understand the operator's manual before using this machine. Failure to follow operating instructions could result in injury or damage to equipment

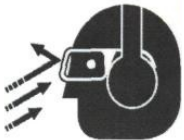

Always wear protective glasses or full face protection



Wear Head Protection, breathing protection, and the use of hearing protection is mandatory



Wear safety boots when operating this machine



SAFETY INSTRUCTIONS

4.0 SAFETY INSTRUCTIONS

4.1 KNOW THE RULES & YOUR EQUIPMENT.

Most job sites have rules governing equipment use & maintenance. Before starting at a new work location, check with the supervisor or safety coordinator. Ask about any rules or regulations you need to abide.

OSHA enforces federal laws within the United States that apply to the safe operation, application, & maintenance of equipment on job sites. It is the employer's responsibility to comply with these laws.

Do not operate this machine unless you have read the operations and maintenance manual carefully.

4.2 RECEIVE PROPER TRAINING.

Do not operate this machine unless you have received operational and maintenance training from a U.S. SAWS representative or from an authorized distributor for U.S.SAWS.

4.3 PROTECT YOUR FEET.

Observe all applicable local, state and federal safety regulations. Wear OSHA approved foot protection.

4.4 PROTECT YOUR EYES.

Observe all applicable local, state and federal safety regulations. Wear OSHA approved safety glasses.

4.5 PROTECT YOUR LUNGS.

Breathable silica may be generated by use of this product. Silica can cause severe and permanent lung damage, cancer, and other serious diseases. Do not breathe the dust. Do not rely on your sight or smell to determine if the dust is in the air. Silica may be in the air without a visible dust cloud. If air monitoring equipment for silica is not provided by your employer at your work site, you **MUST** wear appropriate respiratory protection when using or servicing the machine. Consult your employer and OSHA regarding the appropriate respiratory protection.

4.6 PROTECT YOUR HEARING.

Observe all applicable local, state and federal safety regulations. Wear OSHA approved hearing protection.

4.7 DRESS PROPERLY.

Do not wear loose clothing or jewelry that can be caught in moving parts. Wear protective hair covering to contain long hair. Keep hair away from motor air vent. Rubber gloves and non-skid footwear are recommended when working outdoors.

4.8 AVOID A DANGEROUS ENVIRONMENT.

Do not expose machine to rain. Do not use machine in wet conditions. Water entering a power tool will increase the risk of electric shock. Keep work area well lit. When working at an elevated location, pay attention to articles and persons below. If operating

the power tool in damp locations is unavoidable, use a Ground Fault Circuit Interrupter (GFCI) protected supply. Use of an GFCI reduce the risk of electric shock.

4.9 ELECTRICAL SAFETY

Power tool plugs must match the outlet. Never modify the plug in any way. Do not use any adapter plugs with earthed (grounded) power tools. Unmodified plugs and matching outlets will reduce the risk of electric shock.

Avoid body contact with earthed or grounded surfaces such as pipes, radiators, ranges and refrigerators. There is an increased risk of electric shock if your body is earthed or grounded.

4.10 ELECTRICAL CORD MANAGEMENT

Do not abuse the cord. Never use the cord for carrying, pulling or unplugging the power tool. Keep cord away from heat, oil, sharp edges or moving parts. Damaged or entangled cords increase the risk of electric shock. When operating a power tool outdoors, use an extension cord suitable for outdoor use. Use of a cord suitable for outdoor use reduces the risk of electric shock.

4.11 AVOID ANY AREAS OR ACTIONS THAT EXPOSE YOU TO CARBON MONOXIDE.

Exhaust gas from gasoline engines contains dangerous carbon monoxide. Breathing it can cause unconsciousness and even kill you. Always operate gasoline engine machines in a well-ventilated area. Do not operate in areas where exhaust fumes could accumulate without wearing appropriate respiratory protection. Consult your employer and OSHA regarding the use of an appropriate respirator for dangerous carbon monoxide gases.

4.12 KEEP WORK AREA CLEAN. DO NOT RUN OVER ANYTHING.

Loose objects could be thrown from crack. Make sure area to be cut is clear from people and any loose objects, nuts, bolts, etc. Never run over any loose objects.

4.13 KEEP CHILDREN AND VISITORS AWAY.

Do not allow anyone to stand in line with the blade path. Do not let children or visitors contact machine or extension cord. Keep children and visitors away from the work area.

4.14 KEEP FIRM GRIP ON MACHINE.

Keep a firm hold on the handle grips and maintain control of the machine until the blade completely stops.

4.15 SHUT OFF MACHINE.

When not in use, before servicing and when changing accessories, shut off engine. Release the lever switch and move the on/off switch to the OFF position. Move the fuel valve lever to the OFF position.



SAFETY INSTRUCTIONS

4.16 STORE IDLE EQUIPMENT.

The machine and tools should be stored in a dry and secure location when not in use. Keep equipment out of reach of children.

4.17 OBTAIN SAFETY DATA SHEET (SDS) FOR ALL WORKSURFACE MATERIALS.

This includes primers, all coatings, adhesives, tile and crack filling materials, etc. Do not attempt to cut, clean out or remove material without SDS information. Consult SDS sheet for hazards information. Be aware that some materials are explosive as a dust.

4.18 DO NOT OVERREACH.

Keep proper footing and balance at all times.

4.19 MAINTAIN MACHINE WITH CARE.

Keep machine clean and follow maintenance procedures for better and safer performance. Keep handles dry, clean, and free from oil and grease. Follow instructions for lubricating and changing accessories.

4.20 REMOVE ADJUSTING TOOLS.

Form a habit of checking to see that tools such as adjusting wrenches are removed from the machine and properly stored before starting the engine.

4.21 STAY ALERT.

Watch what you are doing. Use common sense. Do not operate machine when you are tired or fatigued.

4.22 DO NOT USE DRUGS, ALCOHOL, MEDICATION.

Do not operate machine while under the influence of drugs, alcohol, or any medication.

4.23 KEEP THE RIGHT PARTS IN THE RIGHT POSITIONS.

Do not operate machine with parts missing or improperly mounted.

4.24 CHECK DAMAGED PARTS.

Verify all machine guards are in good condition and will function properly before using the machine. Check for alignment of moving parts, binding of moving parts, breakage of parts, mounting, and any other conditions that may affect machine operation. A guard, power switch or other part that is damaged should be properly repaired or replaced by an authorized service center unless indicated elsewhere in this instruction manual. Do not operate machine if lever or engine on/off switch does not function properly.

4.25 SECURELY MOUNT ACCESSORIES TO THE MACHINE.

Extra care must be taken an elevated location to prevent injury to someone on a lower level in the event the tool or accessory should drop. Do not operate without fall protection for operator and debris protection for public.

4.26 NEVER TOUCH THE MOVING PARTS.

Never touch moving parts such as blades, belts and others.

4.27 STOP OPERATION IMMEDIATELY IF ANY ABNORMALITY IS DETECTED.

Stop using machine immediately if any abnormalities are observed during operation. Examples of abnormalities include unusual noise and vibration.

4.28 WHEN REPLACING A PART, USE THE SAME TYPE AND QUALITY.

When replacing a component part with a new one, use only the same type and quality of new part. Never attempt to repair a machine if you are unfamiliar with proper procedures and techniques required.

4.29 LOAD AND UNLOAD SAFELY.

Use proper heavy lifting procedures. Read & understand manuals before loading & unloading.

4.30 SAVE THESE INSTRUCTIONS.

Refer to this operations and maintenance manual as well as any additional instructions included from other manufacturers and organizations such as Metabo® and the Masonry and Concrete Saw Manufacturers Institute®. Never permit anyone to operate the machine without proper instructions.



DUST WARNING

Cutting, especially when DRY cutting, generates dust that comes from the material being cut, which frequently contains silica.

Silica is a basic component of sand, quartz, brick clay, granite and numerous other minerals and rocks. Exposure to excessive amount of such dust can cause:

- Respiratory diseases (affecting your ability to breath), including chronic bronchitis, silicosis and pulmonary fibrosis from exposure to silica. These diseases may be fatal;
 - Skin irritation and rash; and
 - Cancer according to NTP* and IARC*
- * National Toxicology Program, International Agency for Research on Cancer

Take precautionary steps

- Avoid inhalation of and skin contact with dust, mist and fumes;
- Wet cut when feasible, to minimize dust;
- Wear and ensure that all bystanders wear appropriate respiratory protection such as dust masks designed to filter out microscopic particles. (See OSHA 29 CFR Part 1910.1200)

California Prop 65 Warning: Use of this product can cause exposure to materials known to the State of California to cause cancer and/or birth defects or other reproductive harm.

U.S.SAWS™

SURFACE PREP DIVISION

P: 877-817-6687 F: 813-621-7125
Visit us at www.ussaws.com
sales@ussaws.com



SAFETY & OPERATION INSTRUCTIONS

4.30 No person should attempt to operate this machine without first being trained in the operation of industrial cutting and grinding tools. These instructions are not intended as a substitute for training experience. The operator must observe safeguards that include, but are not limited to, the following:

- DO NOT MODIFY ANY MACHINE FROM IT'S ORIGINAL DESIGN WITHOUT THE WRITTEN PERMISSION OF THE MANUFACTURER. UNAUTHORIZED MODIFICATIONS CAN LEAD TO SERIOUS INJURY OR DEATH TO YOURSELF OR OTHERS.
- DO NOT use any cup wheel or grinding disk marked for less than 6,600 - 8,500 RPM.
- DO NOT service the machine or change cup wheel or grinding disk without first disconnecting the power.
- DO NOT install a cup wheel or grinding disk before inspecting the part for damage.
- DO NOT operate with a damaged cup wheel or grinding disk. A damaged cup wheel or grinding disk may fly apart and cause serious injury or death.
- DO NOT use a cup wheel or grinding disk that wobbles when mounted.
- Verify cup wheel or grinding disk is correct for application before use.
- Verify cup wheel or grinding disk rotation matches the direction arrow on the grinder motor.
- DO NOT apply power to the machine before spinning the cup wheel or grinding disk by hand to check alignment.
- DO NOT operate with any loose nuts or bolts. Check all nuts and bolts for tightness.
- DO NOT operate without appropriate eye, ear, foot, hand, and breathing protection.
- DO NOT operate around any loose or foreign objects that may damage the system.
- DO NOT operate if arbor shaft has excessive end play.
- DO NOT grind material that the cup wheel or grinding disk is not designed for.
- DO NOT operate machine near combustible material or fumes.
- DO NOT operate without appropriate dust collection system.
- DO NOT force cup wheel or grinding disk through material to be ground. Always ease cup wheel or grinding disk through material.
- DO NOT operate on not horizontal work surface.

5.0 OPERATION

Assembly of Dust Shroud Onto Grinder

1. Place dust shroud and adaptor around the grinder arbor.
2. Hose nozzle should be at upper right (when looking down on grinder)
3. Slowly tighten the 3 set screws on the adaptor ring in small increments. Make sure that the spacer washer is centered around the blade nut. Tightening one screw all the way down before the other two may cause interference.
4. Ensure the nozzle does not touch the handle mounting bolt. Leave 3/4" gap.

Assembly and Removal of Cup Wheel or Grinding Disk

1. **Make sure power is disconnected.**
2. Using the wrench provided, or a 1 1/2" box wrench, remove the blade nut.
3. Depress the spindle lock on the grinder to stop the spindle from rotating while tightening and loosening the blade nut.
4. Note: both blade nut and arbor nut vary in length, depending on the type of wheel to be used.



PARTS BREAKDOWN

6.0 PARTS BREAK DOWN

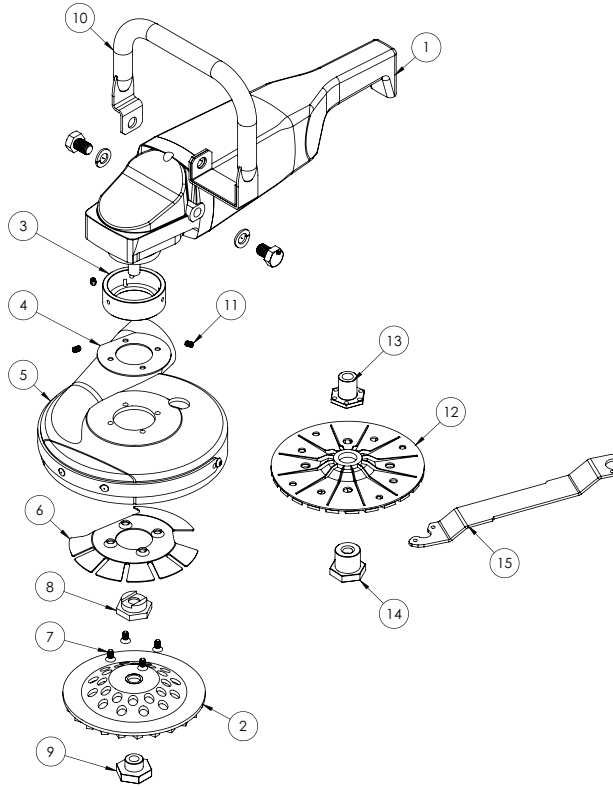

ITEM	QUANTITY	PART NUMBER	DESCRIPTION
1	1	SXW24180 SXW24230	METABO W24-180 8500 RPM 9" ANGLE GRINDER METABO W24-230 6600 RPM 9" ANGLE GRINDER
2	1	CW7TR12SLTB-Black or CW7TR24SDB	7x5/8-11 12 Seg Std Turbo Cup Wheel - Long Thread (30/40 Grit) 7x7/8-5/8 24 Seg Standard Cup Wheel
3	1	SX80640	ADAPTER RING, METABO , "M2"
4	1	SX75820	7" GV SPACER WASHER
5	1	SX65807	7" G2 GRINDER-VAC SHROUD (CONVERTIBLE)
6	1	SX75811	7" GV HOUSING FLANGE SUPPORT
7	4	US31076	1/4"-20x1/2" PHILLIPS FLAT HEAD SCREW
8	1	SX50501M	METRIC B - CV NUT
9	1	SX71100-1	METRIC C1 CUP WHEEL BLADE NUT
10	1	SX73901	7" LOOP HANDLE ASSEMBLY W/BOLTS & LOCK WASHER
11	1	SX50250	1/4-20 x 3/8 SOCKET SET SCREW
12	1	ZEC716L	7" #16 GRIT ZEC LITEX SILICON CARBIDE - NOT INCLUDED
13	1	SX81120	ZEC ARBOR NUT "E"
14	1	SX81130	ZEC ARBOR NUT "F"
15	1	SX60001	2 SIDED SPANNER WRENCH WITH BLACK OXIDE



RECOMMENDED CUP WHEELS

7.0 RECOMMENDED CUP WHEELS

TURBO CUP WHEELS THIN COATING REMOVAL	
Part Number	Description
CW7TR12SDB	7x7/8-5/8 12 Segment Standard Turbo Wheel
CW7TR12SLTB	7x5/8-11 12 Segment Standard Turbo Wheel - Long Thread
CW7TR12PDB	7x7/8-5/8 12 Segment 12 Segment Premium Turbo Wheel
CW7TR12PLTB	7x5/8-11 12 Segment Premium Turbo Wheel - Long Thread
CW7TR24SDB	7x7/8-5/8 24 Segment Standard Turbo Wheel
CW7TR24SLTB	7x5/8-11 24 Segment Standard Turbo Wheel - Long Thread
CW7TR24PDB	7x7/8-5/8 24 Segment Premium Turbo Wheel
CW7TR24PTB	7x5/8-11 24 Segment Premium Turbo Wheel

COATINGS & GENERAL SURFACE PREPARATION Epoxies, Glues, Mastic, Paint, and Abrasive Coatings	
Part Number	Description
CW7SW33DS	7" SWAT 3+3 Cup Wheel - Most Aggressive
CW7SW63DS	7" SWAT 6+3 Cup Wheel - Aggressive with Longer Life
CW7SW99DS	7" SWAT 9+9 Cup Wheel - Longest Life
<i>*All SWAT wheels are #18 grit.</i>	

ARROW SEGMENT CUP WHEELS THICK COATINGS - Epoxy, Urethane, And Other Membrane Materials	
Part Number	Description
CW7AR10PDS	7x7/8 10 Segment Arrow Cup Wheel
CW7AR10PTS	7x5/8-11 10 Segment Arrow Cup Wheel

PCD WHEELS THICK COATINGS - Epoxy, Urethane, Carpet Glue, VCT Glue, And Other Membrane Materials	
Part Number	Description
CW7PCD6R	7"PCD Quarter Round 6 Segment
CW7PCD63PM	7x7/8 PCD Quarter Round 6 Segment with 3 Sweeper Segments. Comes with Threaded Adapter



WARRANTY & SERVICE

8.0 WARRANTY AND SERVICE

8.1.1 Warranty

This document is to be used as a guide in determining warranty policies and procedures for U.S.SAWS and its U.S.SAWS products. It is to be used in determining whether a warranty is justified and as a procedural guide in completing a U.S.SAWS warranty claim form.

8.1.2 Warranty Responsibility

The distributor or the end user must prepare a Machine Warranty Information Card when the machine is delivered. Failure to comply will make any and all warranties on this equipment null and void. Credit for warranty repairs will be given only after receipt of the WARRANTY CLAIM FORM, properly completed with all the required details. Submittal details are described later in this document.

8.1.3 Warranty Policy

8.1.3.1 U.S.SAWS warrants its U.S.SAWS products against defects in material and workmanship under normal and proper use for a period of one year (365) days from the date of delivery; in the case of Rental Fleet Machines, date of assignment to Rental Fleet. Such warranty is extended only to the buyer who purchases the equipment directly from U.S.SAWS or its authorized distributor. This warranty does not include expendable parts such as, but not limited to, plugs, cutters, blades, blast wheel, wear parts, liners and seals.

8.1.3.2 The obligation under this warranty is strictly limited to the replacement or repair, at US SAWS's option, of machines and does not include the cost of transportation, loss of operating time, or normal maintenance services.

8.1.3.3 This warranty does not apply to failure occurring as a result of abuse, misuse, negligence, corrosion, erosion, normal wear and tear, alterations or modifications made to the machine without express written consent of U.S.SAWS .

8.1.3.4 Warranty request must be submitted in writing within thirty (30) days after failure.

8.1.3.5 Written authorization to return merchandise under warranty must first be obtained from U.S.SAWS .

8.1.3.6 U.S.SAWS reserves the right to inspect and make the final decision on any merchandise returned under warranty.

8.1.3.7 U.S.SAWS offers no warranty with respect to accessories, including but not limited to, engines, motors, batteries, electrical boards, tires and any other parts not manufactured by us but which the original manufacturer warrants.

8.1.3.8 U.S.SAWS reserves the right to make product changes or improvements without prior notice and without imposing any obligation upon itself to install the same on its products previously sold.

8.1.3.9 The above warranty conditions can only be altered by US SAWS. US SAWS must confirm alterations in writing for each specific transaction.

8.1.3.10 U.S.SAWS reserves the right to establish specific warranty terms for used or demo machines on an individual transaction basis. Invoices covering such merchandise will clearly state the provisions of the applicable warranty for each specific transaction.

8.1.3.11 WE DO NOT AUTHORIZE ANY PERSON, REPRESENTATIVE OR SERVICE OR SALES ORGANIZATION TO MAKE ANY OTHER WARRANTY OR TO ASSUME FOR US ANY LIABILITY IN CONNECTION WITH THE SALE OF OUR PRODUCTS OTHER THAN THOSE CONTAINED HEREIN.

8.1.3.12 UNDER NO CIRCUMSTANCES SHALL US SAWS BE LIABLE TO CUSTOMER OR ANY OTHER PERSON FOR ANY DIRECT, INCIDENTAL, OR CONSEQUENTIAL DAMAGES RESULTING FROM THE USE OF THE PRODUCT OR ARISING OUT OF ANY BREACH OF ANY WARRANTY OR FOR ANY SPECIAL OR CONSEQUENTIAL DAMAGES OF ANY CHARACTER, INCLUDING WITHOUT LIMITATIONS, DAMAGES FOR ANY LOSS OF GOODWILL, WORK STOPPAGE, OR ANY AND ALL OTHER COMMERCIAL DAMAGES OR LOSSES.

8.1.3.13 U.S.SAWS MAKES NO OTHER WARRANTIES, EXPRESSED OR IMPLIED, INCLUDING, BUT NOT LIMITED TO, THE IMPLIED WARRANTIES OF MERCHANTABILITY AND FITNESS FOR A PARTICULAR PURPOSE WITH RESPECT TO THE US SAWS PRODUCTS SOLD PURSUANT THERETO.



MACHINE WARRANTY INFORMATION CARD

TO ENSURE THE PROPER WARRANTY COVERAGE IS EXTENDED TO THE OWNER OF THIS MACHINE, FILL OUT THE ATTACHED CARD COMPLETELY AND ACCURATELY.

WARRANTY REGISTRATION CARD

IMPORTANT! To ensure that your U.S.SAWS machine is covered under warranty, please fill in the following information and mail or fax it to U.S.SAWS, 8004-B E Broadway Avenue Tampa, FL 33619, Fax No. (813) 621-7125

COMPANY
NAME
ADDRESS
INTENDED USE
DATE OF PURCHASE
INTENDED USE
SERIAL NUMBER

If you are not the owner of record as shown on the manual copy of the warranty registration card, do not operate this machine before contacting U.S.SAWS at 1-877-817-6687. Verify the following before operating the equipment:

CHANGE OF OWNER OR NEW ADDRESS REGISTRATION CARD

IMPORTANT! To ensure that your U.S.SAWS machine is covered under warranty, please fill in the following information and mail or fax it to U.S. SAWS, 8004-B E Broadway Avenue Tampa, FL 33619, Fax No. (813) 621-7125

COMPANY
NAME
ADDRESS
INTENDED USE
DATE OF PURCHASE
INTENDED USE
SERIAL NUMBER

10

U.S.SAWS™

**SURFACE PREP
DIVISION**

P: 877-817-6687 F: 813-621-7125
Visit us at www.ussaws.com
sales@ussaws.com

