

U.S.SAWS™

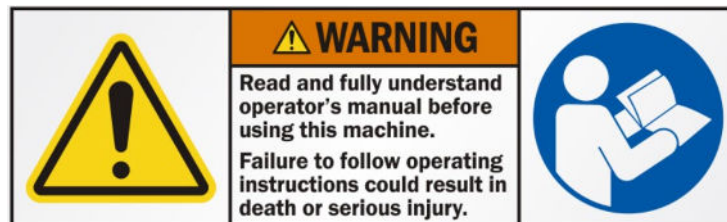

U.S.SAWS ULTRA VAC 1250 OPERATING MANUAL



Notice of Copyright Protection

Copyright 2020, by U.S.SAWS . All rights reserved. This work may not be reproduced or disseminated in whole or in part by any means without the prior written permission of U.S.SAWS

03-01-2022

U.S.SAWS™

**SURFACE PREP
DIVISION**

P: 877-817- 6687 F: 813-621-7125
Visit us at www.ussaws.com
sales@ussaws.com



1.0 INSTRUCTIONS FOR USE OF MANUAL SECTIONS

Section	Page
Table of Contents & Introduction	2
Symbols & Decals	3
Safety Instruction	4 - 5
Operation Checklist	6 - 7
Maintenance&Troubleshooting	7
Parts	8
Warranty & Service	9 - 10

Foreword/Introduction

This manual outlines the maintenance and operation of the Ultra Vac 1250. This is a professional tool and is intended for use by trained and experienced operators. To get maximum benefit from your tool and to ensure maximum safety, be sure to read this manual thoroughly. You should also periodically review safety instructions. Keep all manuals provided with your equipment in a safe place at all times.

The information and specifications included in this publication were in effect at the time of approval for printing. U.S.SAWS reserves the right, however, to discontinue or change specifications or design at any time without notice and without incurring any obligation.

U.S.SAWS Ultra Vac 1250 dust collection system is a lightweight, durable, and easy-to-use industrial vacuum system. This vacuum can handle any surface preparation cleanup projects, small or large. This system is OSHA certified and under table 1 regulations.

Read this entire operations and maintenance manual before using your new tool. Pay close attention to the Rules for safer operation,

Disclosure

By purchasing/renting/borrowing/using the Ultra Vac 1250, you agree to release U.S.SAWS of any and all liability. Under no circumstances will U.S.SAWS be held liable for incidental or consequential damages resulting from the use of this product and/or defective parts or products associated with this product.



2.0 SPECIFICATIONS

Model	Ultra Vac 1250 - HEPA
Part Number	SX50000
CFM	220
Water Lift	110"
Dust Bin	12.5 Gallons
Amperage	17 Amp
Voltage	120V
Filter Size	18.3 sq. ft.
Weight	88 lbs
Hose Inlet Size	2"
Frame / Body	Tube Steel / High Density Polyethylene



SYMBOLS & DECALS

3.0 SYMBOLS & DECALS

For Safe Operation

You must be qualified for safe operation of the U.S.SAWS Ultra Vac 1250 machine. You must clearly understand the written instructions supplied by U.S.SAWS, be trained - including actual operation - & know the safety rules & regulations for the job site. It is a safety practice to point out & explain safety signs & practices to others & to make sure they understand the importance of following these instructions.

Be Safe

Human error is the result of many factors: carelessness, fatigue, sensory overload, preoccupation, unfamiliarity with the machine or attachments, or drugs or alcohol, to name a few. You can avoid serious injury or death caused by these & other unsafe work practices. Be safe and never assume accidents cannot happen to you.

For your safety and the safety of others, act safely and encourage your fellow workers to act safely as well.



Read and understand operator's manual before using this machine. Failure to follow operating Instructions could result in injury or damage to equipment.

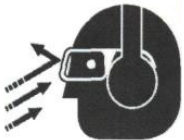

Always wear protective glasses or full face protection



Wear Head Protection, breathing protection, and the use of hearing protection is mandatory



Wear safety boots when operating this machine



Wear appropriate clothing



Wear hand protection



Wear proper electrostatic grounding equipment at all times.



Wear proper electrostatic grounding equipment at all times.

Dangers, Warnings and Cautions.

The purpose of safety symbols and explanations are to attract your attention to possible hazards and how to avoid them. The safety symbols and explanations do not by themselves eliminate any danger. The instructions or warnings they give are not substitutes for proper accident prevention measures.



DANGER: Indicates an imminently hazardous situation that if not avoided, will result in death or serious injury. This signal word is limited to the most extreme situations.



WARNING: Indicates a potentially hazardous situation that, if not avoided, could result in death or serious injury.



CAUTION: Indicates a potentially hazardous situation that, if not avoided may result in minor or moderate injury. It may also be used to alert against unsafe practices that may cause property damage.



SAFETY INSTRUCTIONS

4.0 SAFETY INSTRUCTIONS

4.1 KNOW THE RULES & YOUR EQUIPMENT.

Most job sites have rules governing equipment use & maintenance. Before starting at a new work location, check with the supervisor or safety coordinator. Ask about any rules or regulations you need to abide.

OSHA enforces federal laws within the United States that apply to the safe operation, application, & maintenance of equipment on job sites. It is the employer's responsibility to comply with these laws.

Do not operate this machine unless you have read the operations and maintenance manual carefully.

4.2 RECEIVE PROPER TRAINING.

Do not operate this machine unless you have received operational and maintenance training from a U.S. SAWS representative or from an authorized distributor for U.S.SAWS.

4.3 PROTECT YOUR FEET.

Observe all applicable local, state and federal safety regulations. Wear OSHA approved foot protection.

4.4 PROTECT YOUR EYES.

Observe all applicable local, state and federal safety regulations. Wear OSHA approved safety glasses.

4.5 PROTECT YOUR LUNGS.

Breathable silica may be generated by use of this product. Silica can cause severe and permanent lung damage, cancer, and other serious diseases. Do not breathe the dust. Do not rely on your sight or smell to determine if the dust is in the air. Silica may be in the air without a visible dust cloud. If air monitoring equipment for silica is not provided by your employer at your work site, you **MUST** wear appropriate respiratory protection when using or servicing the machine. Consult your employer and OSHA regarding the appropriate respiratory protection.

4.6 PROTECT YOUR HEARING.

Observe all applicable local, state and federal safety regulations. Wear OSHA approved hearing protection.

4.7 DRESS PROPERLY.

Do not wear loose clothing or jewelry that can be caught in moving parts. Wear protective hair covering to contain long hair. Keep hair away from motor air vent. Rubber gloves and non-skid footwear are recommended when working outdoors.

4.8 AVOID A DANGEROUS ENVIRONMENT.

Do not expose machine to rain. Do not use machine in wet conditions. Water entering a power tool will increase the risk of electric shock. Keep work area well lit. When working at an elevated location, pay attention to articles and persons below. If operating the power tool in damp locations is unavoidable, use a Ground Fault Circuit Interrupter (GFCI) protected supply. Use of an GFCI reduce the risk of electric shock.

4.9 ELECTRICAL SAFETY

Power tool plugs must match the outlet. Never modify the plug in any way. Do not use any adapter plugs with earthed (grounded) power tools. Unmodified plugs and matching outlets will reduce risk of electric shock. Avoid body contact with earthed or grounded surfaces such as pipes,

radiators, ranges and refrigerators. There is an increased risk of electric shock if your body is earthed or grounded.

4.10 ELECTRICAL CORD MANAGEMENT

Do not abuse the cord. Never use the cord for carrying, pulling or unplugging the power tool. Keep cord away from heat, oil, sharp edges or moving parts. Damaged or entangled cords increase the risk of electric shock. When operating a power tool outdoors, use an extension cord suitable for outdoor use. Use of a cord suitable for outdoor use reduces the risk of electric shock.

4.11 AVOID ANY AREAS OR ACTIONS THAT EXPOSE YOU TO CARBON MONOXIDE.

Exhaust gas from gasoline engines contains dangerous carbon monoxide. Breathing it can cause unconsciousness and even kill you. Always operate gasoline engine machines in a well-ventilated area. Do not operate in areas where exhaust fumes could accumulate without wearing appropriate respiratory protection. Consult your employer and OSHA regarding use of appropriate respirator for dangerous carbon monoxide gases.

4.12 KEEP WORK AREA CLEAN. DO NOT RUN OVER ANYTHING.

Loose objects could be thrown from crack. Make sure area to be cut is clear from people and any loose objects, nuts, bolts, etc. Never run over any loose objects.

4.13 KEEP CHILDREN AND VISITORS AWAY.

Do not let children or visitors contact machine or extension cord. Keep children and visitors away from the work area.

4.14 KEEP FIRM GRIP ON MACHINE.

During normal operation as instructed in Section 6.0, keep a firm hold on the handle grips and maintain control of the machine.

4.15 SHUT OFF MACHINE.

When not in use, before servicing and when changing accessories shut off engine.

4.16 STORE IDLE EQUIPMENT.

The machine and tools should be stored in a dry and secure location when not in use. Keep equipment out of reach of children.

4.17 OBTAIN MATERIAL SAFETY DATA SHEET (MSDS) FOR ALL WORK SURFACE MATERIALS.

This includes primers, all coatings, adhesives, tile and crack filling materials, etc. Do not attempt to cut, clean out or remove material without MSDS information. Consult MSDS sheet for hazards information. Be aware that some materials are explosive as a dust.

4.18 DO NOT OVERREACH.

Keep proper footing and balance at all times.

4.19 MAINTAIN MACHINE WITH CARE.

Keep machine clean and follow maintenance procedures for better and safer performance. Keep handles dry, clean, and free from oil and grease. Follow instructions for lubricating and changing accessories.



SAFETY INSTRUCTIONS

4.20 REMOVE ADJUSTING TOOLS.

Form a habit of checking to see that tools such as adjusting wrenches are removed from the machine and properly stored before starting the engine.

4.21 STAY ALERT.

Watch what you are doing. Use common sense. Do not operate machine when you are tired or fatigued.

4.22 DO NOT USE DRUGS, ALCOHOL, MEDICATION.

Do not operate machine while under the influence of drugs, alcohol, or any medication.

4.23 KEEP THE RIGHT PARTS IN THE RIGHT POSITIONS.

Do not operate machine with parts missing or improperly mounted.

4.24 CHECK DAMAGED PARTS.

Verify all machine guards are in good condition and will function properly before using the machine. Check for alignment of moving parts, binding of moving parts, breakage of parts, mounting, and any other conditions that may affect machine operation. A guard, power switch or other part that is damaged should be properly repaired or replaced by an authorized service center unless indicated elsewhere in this instruction manual. Do not operate machine if lever or engine on/off switch does not function properly.

4.25 SECURELY MOUNT ACCESSORIES TO THE MACHINE.

Extra care must be taken an elevated location to prevent injury to someone on a lower level in the event the tool or accessory should drop. Do not operate without fall protection for operator and debris protection for public.

4.26 NEVER TOUCH THE MOVING PARTS.

Never touch moving parts such as blades, belts and others.

4.27 STOP OPERATION IMMEDIATELY IF ANY ABNORMALITY IS DETECTED.

Stop using machine immediately if any abnormalities are observed during operation. Examples of abnormalities include unusual noise and vibration.

4.28 WHEN REPLACING A PART, USE THE SAME TYPE AND QUALITY.

When replacing a component part with a new one, use only the same type and quality of new part. Never attempt to repair a machine if you are unfamiliar with proper procedures and techniques required.

4.29 LOAD AND UNLOAD SAFELY.

Use proper heavy lifting procedures. Read & understand manuals before loading & unloading.

4.30 SAVE THESE INSTRUCTIONS.

Refer to this operations and maintenance manual as well as any additional instructions included from other manufacturers and organizations such as Honda® and the Masonry and Concrete Saw Manufacturers Institute®. Never permit anyone to operate the machine without proper instructions.

4.31 DO NOT SMOKE WHEN OPERATING EQUIPMENT.

Do not vacuum burning, smoking, or smoldering things like cigarettes, matches, or hot ashes. Fire inside the dust pan may occur.

4.32 STAY AWAY FROM FLAMMABLE ITEMS.

Do not use to vacuum flammable liquids, alcohol, gases, or explosive dusts, like gasoline or other fuels, lighter fluid, varnish, polyurethane coatings, cleaners, oil-based paints, natural gas, hydrogen, coal dust, magnesium dust, grain dust, or gun powder. Motors create sparks which may ignite the dust or fumes.

4.33 DO NOT HOLD HOSE DURING OPERATION.

Do not hold the hose against any body parts during operation. Static electricity buildup in the hose during operation may result in static shock.

4.34 MAINTAIN DUST EXTRACTOR WITH CARE.

Properly maintain dust extractor to keep hose unobstructed. Do not put any object into openings. Do not use with any opening blocked; keep free of dust, lint, hair, and anything that may reduce air flow. Any alteration or modification is a misuse and may result in a dangerous condition.



DUST WARNING

Cutting, especially when DRY cutting, generates dust that comes from the material being cut, which frequently contains silica.

Silica is a basic component of sand, quartz, brick clay, granite and numerous other minerals and rocks. Exposure to excessive amount of such dust can cause:

- Respiratory diseases (affecting your ability to breath), including chronic bronchitis, silicosis and pulmonary fibrosis from exposure to silica. These diseases may be fatal;
- Skin irritation and rash; and
- Cancer according to NTP* and IARC*
* National Toxicology Program, International Agency for Research on Cancer

Take precautionary steps

- Avoid inhalation of and skin contact with dust, mist and fumes;
- Wet cut when feasible, to minimize dust;
- Wear and ensure that all bystanders wear appropriate respiratory protection such as dust masks designed to filter out microscopic particles. (See OSHA 29 CFR Part 1910.1200)

California Prop 65 Warning: Use of this product can cause exposure to materials known to the State of California to cause cancer and/or birth defects or other reproductive harm.



OPERATION CHECKLIST

5.0 OPERATION CHECKLIST



Read and understand operator's manual before using this machine. Failure to follow operating instructions could result in injury or damage to equipment.

Warning label - read and understand manual

5.1 This vacuum is designed for intermittent use, i.e. not more than 2 hours continuously. If you are not sure about your application requirements, contact your USSAWS representative.

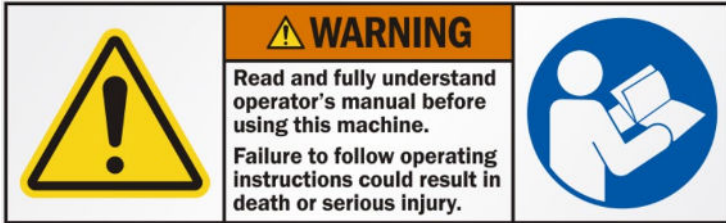

TO PREVENT SERIOUS INJURY DO NOT OPERATE SAW WITHOUT PROPER TRAINING AND UNDERSTANDING OF THE OWNERS MANUAL WHEN OPERATING THIS MACHINE



Wear proper electrostatic grounding equipment at all times.



Wear Head Protection, breathing protection, and the use of hearing protection is mandatory



Flying debris and loud noise hazards. Wear ear and eye protection



Wear hand protection



WARNING: U.S.SAWS vacuums are not to be used for the removal of liquids or of volatile, viscous, flammable, or explosive media. If you are unsure about your application requirements call your local U.S.SAWS representative.



CAUTION: Disconnect the machine from power before and during inspection and/or maintenance.



Wear proper electrostatic grounding equipment at all times. Static discharge during fueling can cause explosion



Static electricity spark hazard. Use static grounding devices.

5.2 VACUUM LOSE SUCTION

5.2.1 When the vacuum begins to lose suction, it means it is full or the filter needs maintenance.

5.2.2 Stop use of your power tool.

5.2.3 Shut the motors off and wait for the motors to stop turning completely to let the dust fall into the collection bin.

5.2.4 Shake the filter shaker back and forth to clean the filter (Note: The shaker handle only needs to travel 2-3 inches and does not need to be "slammed" to the stop point for effective shakedown)

5.2.5 Use your foot to lift up on the dust bin positioning lever and IMMEDIATELY turn one of the motors on. This will prevent airborne dust from escaping to filter cavity. Inspect the level of dust in the bin and empty it if it is more than 3/4 full. Slide dust bin all the way in until it touches the front of the frame, and press the dust bin positioning lever down firmly until the dust bin is locked in place.



WARNING: Carbon monoxide can cause brain damage or death. Engine exhaust contains odorless and colorless carbon monoxide gas. Signs of carbon monoxide poisoning include nausea, headache, dizziness, drowsiness, and lack of consciousness. Get fresh air if anyone shows signs of carbon monoxide poisoning.





WARNING: Wear a two strap respirator when handling silica dust.

5.3 EMPTYING THE DUST BIN

- 5.3.1 Your Ultra-Vac dust bin is made to fit into a heavy duty contractor bag.
- 5.3.2 Lay the contractor bag flat on the ground.
- 5.3.3 Open the end and slide the dust bin inside as far as it will go.
- 5.3.4 Close the end of the bag and tip the dust bin up to empty the dust into the bag.
- 5.3.5 Slowly pull the dust bin out of the bag.
- 5.3.6 Safely dispose of the dust according to local laws. (does not need to be “slammed” to the stop point for effective shakedown)

5.4 LONGOPAC®

- 5.4.1 Shut the vacuum off and allow the dust to fall into the Longopac® bag. Shaking the vacuum can help this.
- 5.4.2 Pull the Longopac® down so there is about a foot of slack.
- 5.4.3 Zip tie 3” apart above the dust.
- 5.4.4 Cut between the zip ties.
- 5.4.5 Safely dispose of the dust according to local laws.

6.0 MAINTENANCE

6.1 BASIC MAINTENANCE

Inspect general condition of vacuum every day. If dust is escaping, stop use immediately and replace main filter.

6.2 FILTER MAINTENANCE

- 6.2.1 The main filter can be removed and cleaned.
- 6.2.2 Clean the filter by flushing with water.
- 6.2.3 Let the filter dry completely before re-installing.
- 6.2.4 DO NOT use a high pressure washer, it can damage the filter
- 6.2.5 DO NOT clean or dry in a clothes washer/dryer.

6.3 TIMED METHOD

- 6.3.1 After repeated use, the operator should start to notice the length of time that passes before the machine starts to lose performance. It is best to perform filter cleaning maintenance at this noted interval to improve the performance of the vacuum.

7.0 TROUBLESHOOTING

7.1 VAC WILL NOT TURN ON

- 7.1.1 Check to see if it is plugged in.
- 7.1.2 Check extension cord, if one is being used.
- 7.1.3 Check circuit breaker. *Ultra Vac 1250 requires it's own dedicated 15AMP circuit*

7.2 LOSS OF SUCTION

- 7.2.1 Filter is clogged. Follow filter cleaning procedures.
- 7.2.2 Hose is clogged. Check vac with hose disconnected to see if there is a clog.
- 7.2.3 Dust bin is not seated correctly. Make sure dust bin is all the way up and seated on the gasket.
- 7.2.4 Filter is wet. This vacuum is NOT designed to pick up liquid or wet debris.



PARTS

ULTRAVAC 1250 and Accessories

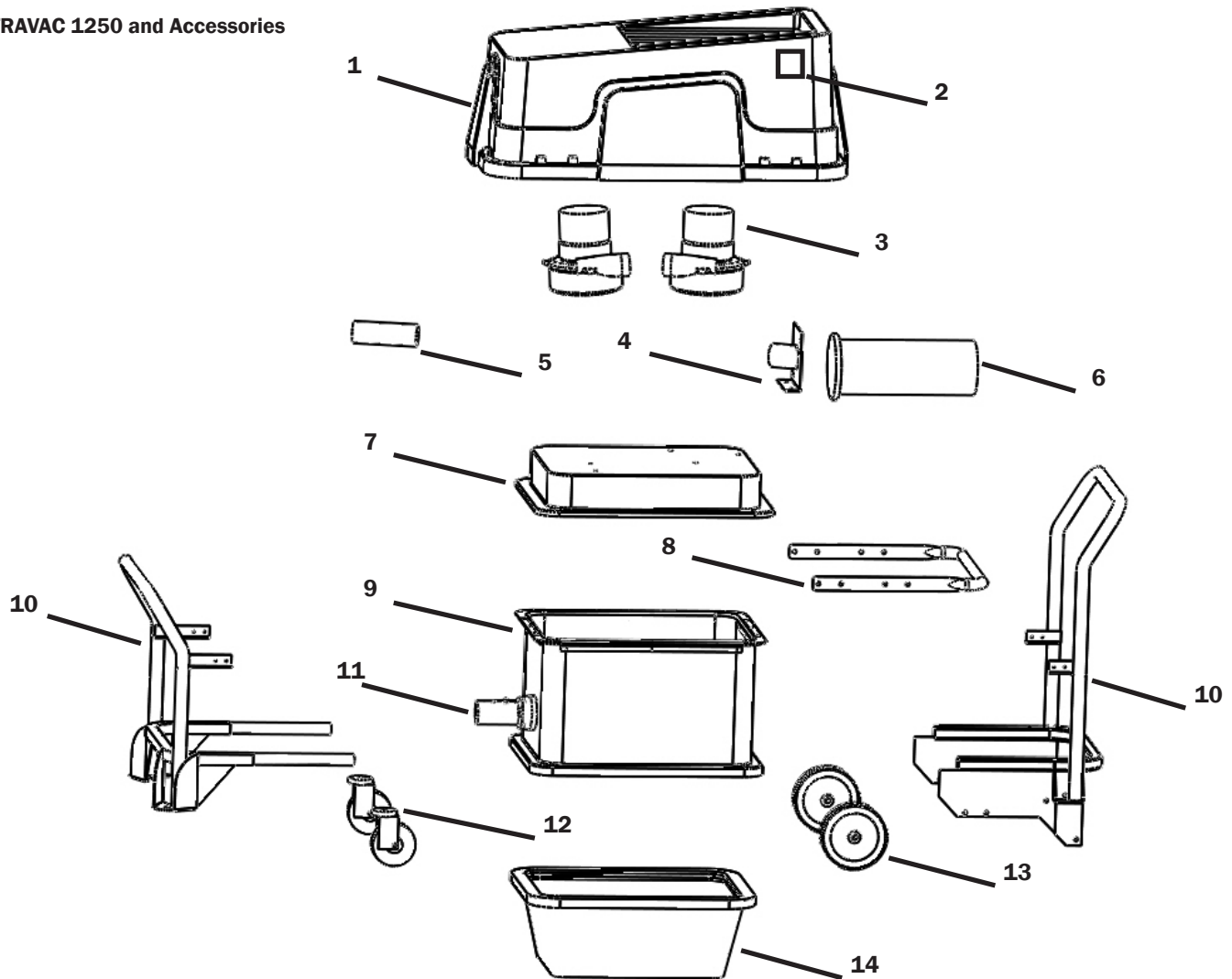

Item	Part Number	Description
1	US24600-1	Motor Cover
2	US24600-31	Motor Switch (2)
3	SX50101	Motor 120V (2)
4	US24600-14C	Filter Bracket
5	US24600-36	HEPA Filter Coupler
6	SX1250/950HEPA	HEPA Filter (Optional) (Qty 2)
7	US24600-15	Motor Mount
8	US24600-9	Dust Bin Position Lever
9	US24600-15.1	Filter Housing
10	SX50100-1	Frame
11	SX24600-60	2" Hose Adapter
12	US24600-23	Front Caster (Qty 2)
13	US24600-24	Rear Wheel (Qty 2)
14	SX24600-6	1250 Dust Bin
Not Pictured	US24600-10	Main Filter
Not Pictured	SX73405	2" Hose, 25 feet



WARRANTY AND SERVICE

8.0 WARRANTY AND SERVICE

8.1.1 Warranty

This document is to be used as a guide in determining warranty policies and procedures for U.S.SAWS and its U.S.SAWS products. It is to be used in determining whether a warranty is justified and as a procedural guide in completing a U.S.SAWS warranty claim form.

8.1.2 Warranty Responsibility

The distributor or the end user must prepare a Machine Warranty Information Card when the machine is delivered. Failure to comply will make any and all warranties on this equipment null and void. Credit for warranty repairs will be given only after receipt of the WARRANTY CLAIM FORM, properly completed with all the required details. Submittal details are described later in this document.

8.1.3 Warranty Policy

8.1.3.1 U.S.SAWS warrants its U.S.SAWS products against defects in material and workmanship under normal and proper use for a period of one year (365) days from the date of delivery; in the case of Rental Fleet Machines, date of assignment to Rental Fleet. Such warranty is extended only to the buyer who purchases the equipment directly from U.S.SAWS or its authorized distributor. This warranty does not include expendable parts such as, but not limited to, plugs, cutters, blades, blast wheel, wear parts, liners and seals.

8.1.3.2 The obligation under this warranty is strictly limited to the replacement or repair, at US SAWS's option, of machines and does not include the cost of transportation, loss of operating time, or normal maintenance services.

8.1.3.3 This warranty does not apply to failure occurring as a result of abuse, misuse, negligence, corrosion, erosion, normal wear and tear, alterations or modifications made to the machine without express written consent of U.S.SAWS .

8.1.3.4 Warranty request must be submitted in writing within thirty (30) days after failure.

8.1.3.5 Written authorization to return merchandise under warranty must first be obtained from U.S.SAWS .

8.1.3.6 U.S.SAWS reserves the right to inspect and make the final decision on any merchandise returned under warranty.

8.1.3.7 U.S.SAWS offers no warranty with respect to accessories, including but not limited to, engines, motors, batteries, electrical boards, tires and any other parts not manufactured by us but which the original manufacturer warrants.

8.1.3.8 U.S.SAWS reserves the right to make product changes or improvements without prior notice and without imposing any obligation upon itself to install the same on its products previously sold.

8.1.3.9 The above warranty conditions can only be altered by US SAWS. US SAWS must confirm alterations in writing for each specific transaction.

8.1.3.10 U.S.SAWS reserves the right to establish specific warranty terms for used or demo machines on an individual transaction basis. Invoices covering such merchandise will clearly state the provisions of the applicable warranty for each specific transaction.

8.1.3.11 WE DO NOT AUTHORIZE ANY PERSON, REPRESENTATIVE OR SERVICE OR SALES ORGANIZATION TO MAKE ANY OTHER WARRANTY OR TO ASSUME FOR US ANY LIABILITY IN CONNECTION WITH THE SALE OF OUR PRODUCTS OTHER THAN THOSE CONTAINED HEREIN.

8.1.3.12 UNDER NO CIRCUMSTANCES SHALL US SAWS BE LIABLE TO CUSTOMER OR ANY OTHER PERSON FOR ANY DIRECT, INCIDENTAL, OR CONSEQUENTIAL DAMAGES RESULTING FROM THE USE OF THE PRODUCT OR ARISING OUT OF ANY BREACH OF ANY WARRANTY OR FOR ANY SPECIAL OR CONSEQUENTIAL DAMAGES OF ANY CHARACTER, INCLUDING WITHOUT LIMITATIONS, DAMAGES FOR ANY LOSS OF GOODWILL, WORK STOPPAGE, OR ANY AND ALL OTHER COMMERCIAL DAMAGES OR LOSSES.

8.1.3.13 U.S.SAWS MAKES NO OTHER WARRANTIES, EXPRESSED OR IMPLIED, INCLUDING, BUT NOT LIMITED TO, THE IMPLIED WARRANTIES OF MERCHANTABILITY AND FITNESS FOR A PARTICULAR PURPOSE WITH RESPECT TO THE US SAWS PRODUCTS SOLD PURSUANT THERETO.



MACHINE WARRANTY INFORMATION CARD

TO ENSURE THE PROPER WARRANTY COVERAGE IS EXTENDED TO THE OWNER OF THIS MACHINE, FILL OUT THE ATTACHED CARD COMPLETELY AND ACCURATELY.

WARRANTY REGISTRATION CARD

IMPORTANT! To ensure that your U.S.SAWS machine is covered under warranty, please fill in the following information and mail or fax it to U.S.SAWS, 8004B E. Broadway Ave. Tampa, FL 33619, Fax No. (813) 621-7125

COMPANY
NAME
ADDRESS
INTENDED USE
DATE OF PURCHASE
INTENDED USE
SERIAL NUMBER

If you are not the owner of record as shown on the manual copy of the warranty registration card, do not operate this machine before contacting U.S.SAWS at 1-877-817-6687. Verify the following before operating the equipment:

CHANGE OF OWNER OR NEW ADDRESS REGISTRATION CARD

IMPORTANT! To ensure that your U.S.SAWS machine is covered under warranty, please fill in the following information and mail or fax it to U.S. SAWS, 8004B E. Broadway Ave. Tampa, FL 33619, Fax No. (813) 621-7125

COMPANY
NAME
ADDRESS
INTENDED USE
DATE OF PURCHASE
INTENDED USE
SERIAL NUMBER

10

