

# U.S.SAWS™



## U.S.SAWS MC-800 OPERATING MANUAL

	<p><b>WARNING</b></p> <p>Read and fully understand operator's manual before using this machine.</p> <p>Failure to follow operating instructions could result in death or serious injury.</p>	
--	--	--

### Notice of Copyright Protection

Copyright 2020, by U.S.SAWS . All rights reserved. This work may not be reproduced or disseminated in whole or in part by any means without the prior written permission of U.S.SAWS

3-25-2026

# U.S.SAWS™

**SURFACE PREP  
DIVISION**

877-817- 6687  
Visit us at [www.ussaws.com](http://www.ussaws.com)  
[sales@ussaws.com](mailto:sales@ussaws.com)



# INTRODUCTION & SPECIFICATIONS

## 1.0 INSTRUCTIONS FOR USE OF MANUAL SECTIONS

Section	Page
Table of Contents & Introduction .....	2
Symbols & Decals .....	3
Safety Instruction .....	4 - 5
Pre-Operation Checklist .....	6 - 8
Operation .....	9 - 10
Parts Breakdown .....	11 - 13
Maintenance & Inspection .....	14 - 15
Propane Power System .....	16 - 19
Warranty & Service .....	20 - 21

### Foreword/Introduction

The owner's manual is intended to point out some of the basic safety situations that maybe encountered during the normal operation & maintenance of the MC-800 Machine & to instruct you in safety practices for dealing with these conditions. Keep all manuals provided with your machine in a safe place at all times.

The information and specifications included in this publication were in effect at the time of approval for printing. U.S.SAWS reserves the right, however, to discontinue or change specifications or design at any time without notice and without incurring any obligation.

The MC-800P "Joint Hog" is a Milling machine designed to remove up to 4" in width and 1-3/4" in depth of concrete to repair spalled joints. It can also be used for grooving, cutting inlays, and to prep for permanent line striping in floors. The blade rotates in an upward direction allowing for easy dust collection when connected to an appropriate vacuum system. The machine should always be operated with a dust collection system and in a well-ventilated area due to carbon monoxide fumes emitted from the gasoline engine.

#### Features:

- Powered by a "certified" Propane 16 HP Vanguard V-Twin engine with an electric start and a CO2 monitor
- Built on the U.S.SAWS JS Series frame
- Frame is fully box welded of high-quality heavy gauge steel
- Solid rear axle serves as the chassis' lifting pivot point for a nearly indestructible platform

Read this entire operations and maintenance manual before using your new tool. Pay close attention to the Rules for safer operation,

### Dangers, Warnings and Cautions.

The purpose of safety symbols and explanations are to attract your attention to possible hazards and how to avoid them. The safety symbols and explanations do not by themselves eliminate any danger. The instructions or warnings they give are not substitutes for proper accident prevention measures.



**DANGER:** Indicates an imminently hazardous situation that if not avoided, will result in death or serious injury. This signal word is limited to the most extreme situations.



**WARNING:** Indicates a potentially hazardous situation that, if not avoided, could result in death or serious injury.



**CAUTION:** Indicates a potentially hazardous situation that, if not avoided may result in minor or moderate injury. It may also be used to alert against unsafe practices that may cause property damage.

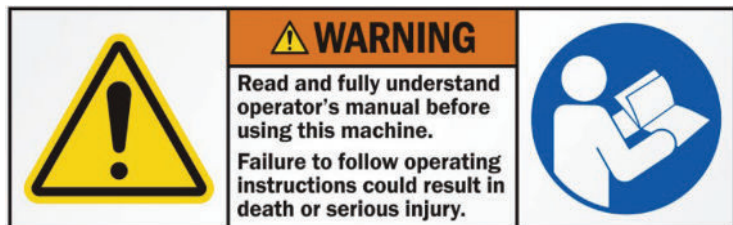

## 2.0 SPECIFICATIONS

MC-800 JOINT HOG SPECIFICATIONS	
Part Number	SX77160WC
Fuel Type	Propane
Engine/ Tank	16 HP Vanguard V-Twin Certified Propane/ Electric Start - Vapor - 20 lb
Max RPM	5,850
Max Cutting Depth	1-3/4" (8" Blade) Fully Adjustable
Max Cutting Width	up to 4"
Minimum Clearance from Wall (side)	3"
Minimum Clearance from Wall (front)	7"
Cutting Speed	2.5 feet per minute at 2" wide 1" deep - full mill
Arbor	1" with Drive Pin Hole
Blade Size	8"
Blade Width	.125 & .150
Dust Collector Size	400+ CFM is recommended
Weight	240 lb



# SYMBOLS & DECALS

## 3.0 SYMBOLS & DECALS

### For Safe Operation

You must be qualified for safe operation of the U.S.SAWS MC-800 machine. You must clearly understand the written instructions supplied by U.S.SAWS, be trained - including actual operation - & know the safety rules & regulations for the job site. It is a safety practice to point out & explain safety signs & practices to others & to make sure they understand the importance of following these instructions.

### Be Safe

Human error is the result of many factors: carelessness, fatigue, sensory overload, preoccupation, unfamiliarity with the machine or attachments, or drugs or alcohol, to name a few. You can avoid serious injury or death caused by these & other unsafe work practices. Be safe and never assume accidents cannot happen to you.

For your safety and the safety of others, act safely and encourage your fellow workers to act safely as well.



Read and understand operator's manual before using this machine. Failure to follow operating Instructions could result in injury or damage to equipment.



Use only diamond blades (steel centered diamond cutting-off wheels) with this machine. RPM rating on blade must exceed machine max rpm rating. The use of any other blade could result in death or serious injury.

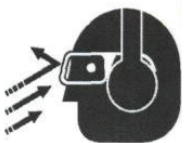

Flying debris and loud noise hazards. Wear ear and eye protection



Engine exhaust contains poisonous carbon monoxide gas. Breathing it could cause death. Operate machine in well ventilated area.



### AVOID INJURY.

Do NOT operate with guard removed. Replace guard before operating machine.



Wear safety boots when operating this machine



Wear appropriate clothing



Wear Head Protection, breathing protection, and the use of hearing protection is mandatory



Wear hand protection



Wear proper electrostatic grounding equipment at all times. Static discharge during fueling can cause explosion

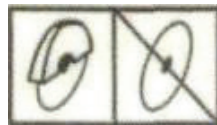

Keep all guards in place



Rotating blade hazard. Do NOT operate with guard up. Keep hands and feet away.



### TO AVOID INJURY.

Always inspect saw blades before use. Replace all cracked or damaged blades.



# SAFETY INSTRUCTIONS

## 4.0 SAFETY INSTRUCTIONS

### 4.1 KNOW THE RULES & YOUR EQUIPMENT.

**Most job sites have rules governing equipment use & maintenance. Before starting at a new work location, check with the supervisor or safety coordinator. Ask about any rules or regulations you need to abide.**

**OSHA enforces federal laws within the United States that apply to the safe operation, application, & maintenance of equipment on job sites. It is the employer's responsibility to comply with these laws.**

Do not operate this machine unless you have read the operations and maintenance manual carefully. Read any additional instructions included from other manufacturers and organizations such as Vanguard and the Masonry and Concrete Saw Manufacturers Institute. Learn the applications and limitations as well as the specific potential hazards related to this tool

### 4.2 RECEIVE PROPER TRAINING.

Do not operate this machine unless you have received operational and maintenance training from a U.S. SAWS representative or from an authorized distributor for U.S.SAWS.

### 4.3 PROTECT YOUR FEET.

Observe all applicable local, state and federal safety regulations. Wear OSHA approved foot protection.

### 4.4 PROTECT YOUR EYES.

Observe all applicable local, state and federal safety regulations. Wear OSHA approved safety glasses.

### 4.5 PROTECT YOUR LUNGS.

Breathable silica may be generated by use of this product. Silica can cause severe and permanent lung damage, cancer, and other serious diseases. Do not breathe the dust. Do not rely on your sight or smell to determine if the dust is in the air. Silica may be in the air without a visible dust cloud. If air monitoring equipment for silica is not provided by your employer at your work site, you **MUST** wear appropriate respiratory protection when using or servicing the machine. Consult your employer and OSHA regarding the appropriate respiratory protection.

### 4.6 PROTECT YOUR HEARING.

Observe all applicable local, state and federal safety regulations. Wear OSHA approved hearing protection.

### 4.7 DRESS PROPERLY.

Do not wear loose clothing or jewelry that can be caught in moving parts. Wear protective hair covering to contain long hair. Keep hair away from motor air vent. Rubber gloves and non-skid footwear are recommended when working outdoors

### 4.8 AVOID A DANGEROUS ENVIRONMENT.

Do not expose machine to rain. Do not use machine in wet conditions. Keep work area well lit. When working at an elevated location, pay attention to articles and persons below.

### 4.9 BEWARE OF HIDDEN DANGERS IN CONCRETE.

Rebar or utility lines may be buried in concrete. Disconnect the power to any utility lines. If these items are to be missed, clearly mark the area. If these items are to be cut, check the blade manufacturer's guidelines on material to be cut.

### 4.10 AVOID ANY AREAS OR ACTIONS THAT EXPOSE YOU TO CARBON MONOXIDE.

Exhaust gas from gasoline engines contains dangerous carbon monoxide. Breathing it can cause unconsciousness and even kill you. Always operate gasoline engine machines in a well-ventilated area. Do not operate in areas where exhaust fumes could accumulate without wearing appropriate respiratory protection. Consult your employer and OSHA

regarding use of appropriate respirator for dangerous carbon monoxide gases.

### 4.11 KEEP WORK AREA CLEAN. DO NOT RUN OVER ANYTHING.

Loose objects could be thrown from crack. Make sure area to be cut is clear from people and any loose objects, nuts, bolts, etc. Never run over any loose objects.

### 4.12 KEEP CHILDREN AND VISITORS AWAY.

Do not allow anyone to stand in line with the blade path. Do not let children or visitors contact machine or extension cord. Keep children and visitors away from the work area.

### 4.13 AVOID FLAMMABLE LIQUIDS OR GASES.

Engines and diamond blades produce heat and sparks during operation. Never use machines in dangerous sites containing flammable, combustible or explosive materials such as lacquer, paint, benzene, thinner, gasoline, gases, and adhesive agents.

### 4.14 AVOID CONTACT WITH HOT MUFFLER.

The muffler becomes hot during operation and remains hot after stopping the engine. Do not touch the muffler while it is hot. Let the engine cool before storing indoors. Do not place flammable objects close to the engine.

### 4.15 AVOID CONTACT WITH HOT BLADE AND BLADE GUARD.

The blade and blade guard become hot during operation and remain hot after stopping the engine. Do not touch the blade and blade guard without proper hand protection.

### 4.16 KEEP FIRM GRIP ON MACHINE.

During normal operation as instructed in Section 6.0, keep a firm hold on the handle grips and maintain control of the machine until the blade completely stops.

### 4.17 SHUT OFF ENGINE.

When not in use, before servicing and when changing accessories shut off engine. Release the lever switch and move the on/off switch to the OFF position. Move the fuel valve lever to the OFF position.

### 4.19 CHECK BLADE AND MACHINE ROTATION DIRECTION.

Never operate a blade in the wrong rotation direction. Check the machine rotation direction and blade direction when mounting a blade.

### 4.20 CHECK BLADE MAXIMUM ALLOWABLE SPEED.

Check the maximum operating speed of the machine and blade. Never use a blade rated less than the machine's maximum speed rating.

### 4.21 CHECK BLADE FOR CRACKS, DAMAGE, AND MISALIGNMENT.

Never use a cracked, damaged, or misaligned blade. After mounting blade, rotate by hand to check for proper alignment.

### 4.22 CHECK DIAMOND BLADE FOR WARNINGS.

Many diamond blades contain a chemical known to the state of California to cause cancer and/or birth defects or other reproductive harm. Diamond blades improperly used are dangerous. Comply with American National Standards Institute Safety Code B71 and Occupational Safety & Health Act covering SPEED, SAFETY GUARDS, FLANGES, MOUNTING PROCEDURES, GENERAL OPERATING RULES, HANDLING, STORAGE & INSPECTION AND GENERAL MACHINE CONDITIONS. Read Diamond Blades Safety Manual before use.

### 4.23 DO NOT FORCE WRONG SIZE OR TYPE BLADE ONTO MACHINE.

Do not force a blade onto the machine shaft or alter the size of the arbor-mounting hole. Be certain that the drive pin is in place through the blade when tightening the blade nut. Never add a drive pin hole or modify a blade.

### 4.24 USE CORRECT SAW AND ACCESSORIES.

Do not force a small saw to do the job of a heavy-duty saw. Do not use the saw for improper applications. Never cut material for which the blade was not designed. Check blade manufacturer's guidelines on material to be cut.



# SAFETY INSTRUCTIONS

## 4.25 STORE IDLE EQUIPMENT.

The machine, blades and tools should be stored in a dry and secure location when not in use. Keep equipment out of reach of children.

## 4.26 DO NOT FORCE SAW.

The saw will do the job better and safer at the rate for which it was designed.

## 4.27 OBTAIN SAFETY DATA SHEET (SDS) FOR ALL WORK SURFACE MATERIALS.

This includes primers, all coatings, adhesives, tile and crack filling materials, etc. Do not attempt to cut, clean out or remove material without SDS information. Consult SDS sheet for hazards information. Be aware that some materials are explosive as a dust.

## 4.28 DO NOT OVERREACH.

Keep proper footing and balance at all times.

## 4.30 MAINTAIN MACHINE WITH CARE.

Keep machine clean and follow maintenance procedures for better and safer performance. Keep handles dry, clean, and free from oil and grease. Follow instructions for lubricating and changing accessories.

## 4.31 REMOVE ADJUSTING TOOLS.

Form a habit of checking to see that tools such as adjusting wrenches are removed from the machine and properly stored before starting the engine.

## 4.32 STAY ALERT.

Watch what you are doing. Use common sense. Do not operate machine when you are tired or fatigued.

## 4.33 DO NOT USE DRUGS, ALCOHOL, MEDICATION.

Do not operate machine while under the influence of drugs, alcohol, or any medication.

## 4.34 KEEP THE RIGHT PARTS IN THE RIGHT POSITIONS.

Do not operate machine with parts missing or improperly mounted.

## 4.35 CHECK DAMAGED PARTS.

Verify all machine guards are in good condition and will function properly before using the machine. Check for alignment of moving parts, binding of moving parts, breakage of parts, mounting, and any other conditions that may affect machine operation. A guard, power switch or other part that is damaged should be properly repaired or replaced by an authorized service center unless indicated elsewhere in this instruction manual. Do not operate machine if lever or engine on/off switch does not function properly.

## 4.36 SECURELY MOUNT ACCESSORIES AND BLADES TO THE MACHINE.

Extra care must be taken when using saws on an elevated location to prevent injury to someone on a lower level in the event the tool or accessory should drop. Do not operate without fall protection for operator and debris protection for public.

## 4.37 NEVER TOUCH THE MOVING PARTS.

Never touch moving parts such as blades, belts and others.

## 4.38 STOP OPERATION IMMEDIATELY IF ANY ABNORMALITY IS DETECTED.

Stop using machine immediately if any abnormalities are observed during operation. Examples of abnormalities include unusual noise and vibration.

## 4.39 WHEN REPLACING A PART, USE THE SAME TYPE AND QUALITY.

When replacing a component part with a new one, use only the same type and quality of new part. Never attempt to repair a machine if you are unfamiliar with proper procedures and techniques required.

## 4.40 NEVER DISABLE THE LEVER.

Do not modify, disable, or attempt to permanently engage the lever. Do not operate a machine if lever is not functioning. This could lead to serious injury or death.

## 4.41 LOAD AND UNLOAD SAFELY.

Use proper heavy lifting procedures. Read & understand manuals before loading & unloading.

## 4.42 STORAGE.

Always store equipment properly when it is not being used. Equipment should be stored in a clean, dry location and out of reach of children.

## 4.43 SAVE THESE INSTRUCTIONS.

Refer to this operations and maintenance manual as well as any additional instructions included from other manufacturers and organizations such as Vanguard and the Masonry and Concrete Saw Manufacturers Institute®. Never permit anyone to operate the machine without proper instructions.



## DUST WARNING

**Cutting, especially when DRY cutting, generates dust that comes from the material being cut, which frequently contains silica.**

Silica is a basic component of sand, quartz, brick clay, granite and numerous other minerals and rocks. Exposure to excessive amount of such dust can cause:

- Respiratory diseases (affecting your ability to breath), including chronic bronchitis, silicosis and pulmonary fibrosis from exposure to silica. These diseases may be fatal;
- Skin irritation and rash; and
- Cancer according to NTP\* and IARC\*

\* National Toxicology Program, International Agency for Research on Cancer

Take precautionary steps

- Avoid inhalation of and skin contact with dust, mist and fumes;
- Wet cut when feasible, to minimize dust;
- Wear and ensure that all bystanders wear appropriate respiratory protection such as dust masks designed to filter out microscopic particles. (See OSHA 29 CFR Part 1910.1200)

California Prop 65 Warning: Use of this product can cause exposure to materials known to the State of California to cause cancer and/or birth defects or other reproductive harm.



# PRE-OPERATION CHECKLIST

## 5.0 PRE-OPERATION CHECKLIST



Read and understand operator's manual before using this machine. Failure to follow operating instructions could result in injury or damage to equipment.

Figure 1 - Warning label - read and understand manual

**5.1** Start by reading the entire Vanguard Engines Owner's Manual, Rx for Diamond Blade Safety, and Rx for Concrete Saws by the Masonry and Concrete Saw Manufacturers Institute. Then, read the entire MC-800 operations and maintenance manual. Get familiar with the machine's parts. See Figure 1 through Figure 32.

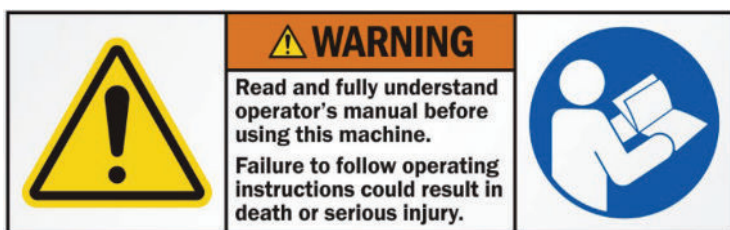

TO PREVENT SERIOUS INJURY DO NOT OPERATE SAW WITHOUT PROPER TRAINING AND UNDERSTANDING OF THE OWNERS MANUAL WHEN OPERATING THIS MACHINE

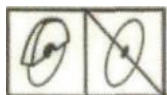

Keep all guards in place



Wear Head Protection, breathing protection, and the use of hearing protection is mandatory



Flying debris and loud noise hazards. Wear ear and eye protection



Wear hand protection



**WARNING:** Improperly maintaining the MC-800 including the Vanguard engine or failing to correct a problem before operation could cause a malfunction resulting in a serious injury. Always perform a pre-operation inspection before each operation and correct any problem. See Vanguard Engines Owner's Manual.

**5.2** Check the condition of the Vanguard engine. See the section titled "Before operation - is your engine ready to go?" in the Vanguard Engines Owner's Manual.



### AVOID STATIC ELECTRICITY RISK

**WARNING:** Ultra-Low Sulfur Diesel (ULSD) poses a greater static ignition hazard. Consult with your propane supplier to ensure the delivery system is in compliance with fueling standards for proper grounding and bonding practices. Maintaining a discharge strap must be connected to any U.S.SAWS vacuum at all times when equipment is being used.



Wear proper electrostatic grounding equipment at all times. Static discharge during can cause explosion



**WARNING:** Exhaust gas engines contains dangerous carbon monoxide. Breathing it can cause unconsciousness and even kill you. Always operate in a well-ventilated area. Do not operate in areas where exhaust fumes could accumulate without wearing appropriate respiratory protection. Consult your employer and OSHA regarding use of appropriate respirator for dangerous carbon monoxide gases. See Figure 7.



Engine exhaust contains poisonous carbon monoxide gas. Breathing it could cause death. Operate machine in well ventilated area.

Figure 2 - Warning label - engine exhaust contains carbon monoxide gas 11

**5.3** Observe the condition of your work environment. Walk over area work area and look for hazards. Make sure the work environment is safe and meets all safe-working conditions discussed in section 4, Rules for safer operation.

**5.4** Obtain SAFETY DATA SHEET (SDS) for all work surface materials. This includes primers, all coatings, adhesives, tile and crack filling materials, etc. Do not attempt to cut, clean out, or remove material without SDS information. Consult SDS sheet for health hazards information. Be aware that some materials are explosive as a dust



**WARNING:** The MC-800 maximum blade operating speed is 5,850 rpm as labeled on the blade guard. Use only dry cut diamond blades rated higher than 5,850 rpm safe operating speed. Do not use a blade rated for less than 5,850 rpm. Do not use a blade that is not a dry cut diamond blade. Using a non dry cut diamond blade or a blade rated below 5,850 rpm could result in severe blade failure, personal injury or death. See Figure 8 and Figure 9. Never cut material for which the blade was not designed. Check blade manufacturer's guidelines on material to be cut. Never operate a blade in the wrong rotation direction. Verify blade direction when changing blades. The MC-800 is designed to cut in a straight line. Never attempt to cut any pattern or follow any joint that is not a straight line.



# PRE-OPERATION CHECKLIST

## 5,850 MAX. RPM

Figure 3 - Max rpm label - maximum blade speed

5.5 Choose the proper dry cut diamond blade for the application, speed and material to be cut. See Figure 9.



### WARNING

Use only diamond blades (steel centered diamond cutting-off wheels) with this machine. RPM rating on blade must exceed machine max rpm rating. The use of any other blade could result in death or serious injury.

Figure 4 - Warning label - use only diamond blades

5.5 Clearly mark all intended cut areas with straight paint or chalk lines.

5.6 Verify that the lever is disengaged or released, and the Vanguard engine switch and fuel valve lever are in the OFF position. Make sure blade is completely stopped.

### CAUTION

**CAUTION:** Running the MC-800 generates heat in the engine, blade and blade guard. Do not touch these components without wearing proper heat protecting work gloves.

5.7 Remove bolt in the blade guard holding bracket. Hold the blade guard firmly and raise guard up into the holding bracket. Reinsert bolt in the blade guard holding bracket and tighten nut.

5.8 Remove both blade change wrenches from the MC-800 handle. Install dry cut diamond blade. See section 7.1 for detailed instructions on removing and installing blades. Inspect diamond blades for damage at least twice daily and before each use. Damaged diamond blades are hazardous and should never be used on a MC-800.

### WARNING



#### TO AVOID INJURY.

Always inspect saw blades before use. Replace all cracked or damaged blades.

Figure 5 - Warning label - inspect blades before use

5.9 Replace the wrenches in the holding bracket on the handle. Tighten the wrench-clamping knob.

5.10 Check the belt tension each day before starting work. Check after the first hour of operation if the MC-800 or belt is new. See section 7.3 for detailed instructions on checking and adjusting the belt tension.

5.11 Move the front and rear pointer arms down towards the ground. Turn the height adjustment handle clockwise until the blade touches the ground. Now turn the adjustment handle counter-clockwise one complete 360° turn. This will raise the blade slightly off the ground.

5.12 Using the marked chalk line or any straight line on the ground, align the blade with the line. On the pointer wheels, loosen the adjustment nuts and align the wheels with the same chalk line. Push the MC-800 along the line to verify the alignment is straight. See Figure 11 and Figure 12.

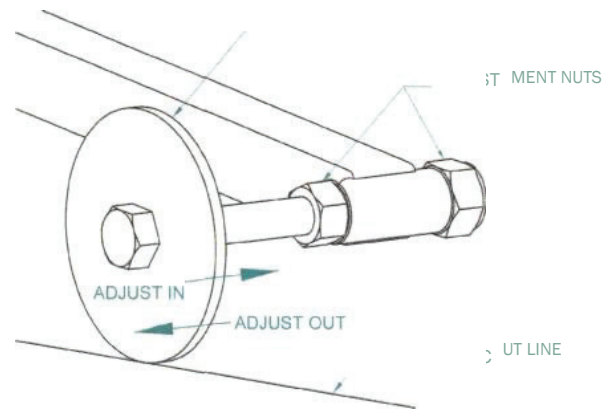

Figure 6 - Pointer wheel adjustment

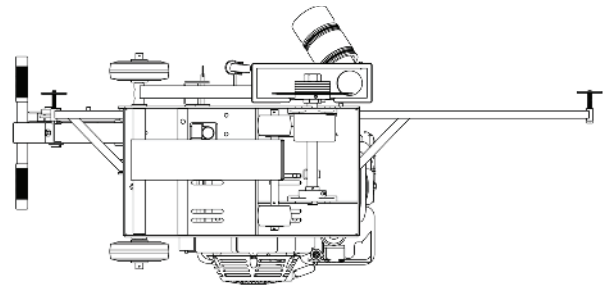

Figure 7 - Alignment of blade and the pointer wheels - JS bottom view



# PRE-OPERATION CHECKLIST

## CAUTION

**CAUTION:** The blade depth is approximate and not exact. Many variables affect the exact blade depth such as the exact diameter of a worn diamond blade. If an accurate depth must be cut, install the blade to be used with the engine in the OFF position. Place the MC-800 in a secure position that allows the blade to overhang and be visibly measured at full blade depth. An example would be blocking the wheels with the engine in the OFF position and lowering the MC-800 blade along side a street curb. This will allow a measurement from the bottom of the blade to the top of the curb.

**5.14** Hold the blade guard firmly and remove the bolt in the blade guard holding bracket. Lower the blade guard down until the 2" caster wheel touches work surface. Reinsert bolt in the blade guard holding bracket for future use.

**5.15** Make sure the blade guard caster wheel and white dust urethane seal at the blade guard base are firmly touching the work surface. See section 7.2 for detailed instructions on adjusting the dust urethane seal and urethane seal guard caster wheel.

## WARNING

**WARNING:** Breathable silica may be generated by use of this product. Silica can cause severe and permanent lung damage, cancer, and other serious diseases. Do not breathe the dust. Do not rely on your sight or smell to determine if the dust is in the air. Silica may be in the air without a visible dust cloud. If air monitoring equipment for silica is not provided by your employer at your work site, you **MUST** wear appropriate respiratory protection when using or servicing the machine. Consult your employer and OSHA regarding the appropriate respiratory protection.

**5.16** Slide the 3" diameter vacuum hose over the connector and tighten the worm drive hose clamp. Pull firmly on the hose to verify the connection will not slide off.

**5.17** Check for missing or loose bolts. Tighten loose bolts and replace missing bolts before operating machine. Verify that belt and blade guards are in place. Never operate a MC-800 without guards in place. See Figure 14 and Figure 15.

## WARNING

**5.18** **WARNING:** If you can see the drive belt or diamond blade, the guards are not in place. Never operate a MC-800 without guards in place. The proper position for the belt guard is bolted with four bolts to the chassis. The proper position for the blade guard is down with the white guard dust brush touching the horizontal surface. See Figure 14 and Figure 15.

**5.19** Dress properly. Wear ear and eye protection. See sections 4.3 through 4.7. See Figure 16

**5.20** MC-800 premium dry cut diamond blades, medium bond

## WARNING

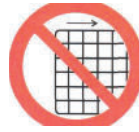

### AVOID INJURY.

Do NOT operate with guard removed. Replace guard before operating machine.

**Figure 8 - Warning label - do not operate with guard removed**

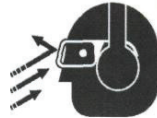

Flying debris and loud noise hazards. Wear ear and eye protection

**Figure 10 - Warning label - wear proper clothing, ear and eye protection**

## WARNING

**WARNING:** Recommended accessories for this tool including blades are listed in this manual or are available by calling customer service. The use of any other attachment or accessory might be hazardous



Rotating blade hazard. Do NOT operate with guard up. Keep hands and feet away.

**Figure 9 - Warning label - do not operate with guard up**



Wear appropriate clothing



# OPERATION

## 6.0 OPERATION

The **U.S.SAWS** MC-800 saws are designed for the purpose of:

- cleaning out existing control joints
- Removing existing joint fill material
- Cutting concrete to remove deteriorated concrete for joint rebuilding

Each one of these tasks is unique in nature and require different blade configurations.

### **MC-800 Blade Installation:**

To install the blades on the MC800 remove the flanges and spacers. Install the first blade directly against the inner flange of the blade shaft assembly. Install a spacer of the desired width and then another blade and repeat the process until the desired width of cut is achieved. The MC 800 can use one blade or up to 16 blades to achieve a maximum width of four inches. When the desired width of cut is achieved install additional spacers so that the blade nut has enough threads to tighten the assembly but not hit the inside of the blade guard. There may be leftover spacers which should be stored in a safe place for later use. The outer flange has a groove cut on the inside of it that helps keep the blades tight and also assists in loosening the blade when blade changes need to be made. It is essential that the blade nut is tight and the drive pin nut is also tight. You may need to use an alternating tightening sequence to achieve tightness in both fasteners. A common way to achieve this is to tighten the blade nut then tighten the drive pin nut and then recheck the tightness of the blade nut and finally recheck the tightness of the blade nut.

Please visit the US Saws YouTube page for a blade installation video if further information is needed.

### **Operation:**

The MC 800 is designed to be used by one operator however it is often helpful to have a helper available to move hoses, the vacuum, and obstacles in the path of the cut.

### **Setting the depth of cut:**

With the machine in the off position use the cut engage disengage lever to lower the blades until they are just barely making contact with the floor. Use the depth control Jack to achieve this. You may need to raise and lower the blades several times to get the machine leveled. Raise this the blades with the cut engage lever and use the depth control Jack to set the depth by turning the Jack one rotation for every quarter inch of depth. Once the depth is set you must make an initial cut to check for accuracy. Do this by starting the saw and lowering the blades into the cut and then pulling the blades out of the cut, shut the saw off, move it and check the depth of the cut you just made and adjust if necessary.

### **Starting the engine:**

When starting the engine the blades should be raised and all guards should be in place.

Open the valve on the propane tank.

Set the throttle to ½ turn the ignition key to start the engine.

Allow the engine to warm up for approximately 30 seconds at half throttle. Once the engine is warm you may increase the throttle to full speed and begin your cut.

If the engine is running rough it may be low on propane or may need air filter service.

### **Cutting/Milling:**

Slowly lower the blade stack into the concrete. Do not drop it or force it. Be prepared for the machine to push back against the operator until full depth is achieved. Once the blades have reached full depth the operator may begin pushing the machine forwards. It is worth noting that this machine is very slow moving forward. The deeper and wider you cut the slower it will go. Use patience and allow the diamond blades to do the cutting. Excessive force will create excessive heat and damage the diamond blades. This machine is intended to be used by a fully capable adult that has both strength and equipment operation knowledge and experience.

### **Dust collection:**

This machine must use a dust collector that has a minimum of 350 CFM. It is important to note the inside of the blade guard has a plenum type dust collection port. If dust is escaping there may be debris in the plenum. Periodically shut the saw off and check if dust is not being collected efficiently. Removal of polyurea joint fill will also cause blockage from time to time.

When overlapping cuts it may be necessary to use a smaller less powerful vacuum in addition to the main vacuum to collect dust if a portion of the blade guard is overhanging a previous cut.



# OPERATION

- 6.1 Follow all pre-operating instructions in section 5.0.
- 6.2 Turn handle counterclockwise until jack assembly upper arm is above the highest depth slot. This will allow proper clearance between the work surface and the blade tip.



**WARNING:** Never attempt to start the engine with the diamond blade inserted in a joint or previous cut. The blade will turn as soon as the MC-800 is started. This could damage the blade or cause the MC-800 to jump backwards.

- 6.3 Turn on the vacuum system.
- 6.4 Move the Vanguard engine fuel valve lever to the ON position.
- 6.5 To start a cold engine, move the choke lever to the CLOSED position. To restart a warm engine, leave the choke lever in the OPEN position.
- 6.6 Move the throttle lever away from the SLOW position, about 1/3 of the way toward the fast position.
- 6.7 Turn the engine switch to the ON position.
- 6.8 Stand on the side of the JS opposite the blade guard. With the left hand, pull the starter cord grip lightly until you feel resistance, then pull briskly. Return the starter grip gently. Repeat until engine starts. If engine does not start, see section 7.5 for maintenance.
- 6.9 If the choke lever has been moved to the CLOSED position to start the engine, gradually move it to the OPEN position as the engine warms up.
- 6.10 While continuing to squeeze the lever, switch the right hand with the left hand. In other words, your left hand will now be on the left handle grip and squeezing the lever. This will free your right hand. Warren to provide new copy.
- 6.11 Using your left hand on the handle pull back and downwards on the handle to reduce the weight on the front wheels while at the same time using your right hand to release the depth stop and gently lower the lifting handle the blade into the joint.
- 6.12 Cut with the machine for a few inches. Pull back on the handle with your left hand in the same way as 6.11 above while at the same pulling back on the lifting hand, then release the lock so the machines rest out of the cut then turn the machine off.
- 6.13 Measure the depth of cut and adjust as necessary.



**WARNING:** Do not twist the blade in the cut. Never attempt to cut any pattern or follow any joint that is not a straight line. Do not force the blade forward. These actions could damage the blade and MC-800 unit.

- 6.14 Proceed to clean out the joint as required. Remove blade from the cut as described in 6.12.
- 6.15 In the event of an emergency related to the blade, step to the left of the machine and turn the Motor OFF if possible.



**WARNING:** Beware that after releasing the lever, the blade will continue spinning for several seconds. Keep a firm hold on the handle grips and maintain control of the machine until the blade completely stops.

- 6.16 For normal shut down. Pull the saw blade out of the cut by pulling back on the handle with your left hand, while at the same pulling back on the lifting handle, then release the lock so the machines rest out of the cut then turn the machine off.
- 6.17 For any other emergency, such as fire, use the normal procedure above, 6.16, to pull the saw blade out of the cut.



# PARTS BREAKDOWN

6.18 Figure 18 to Figure 23 of MC-800

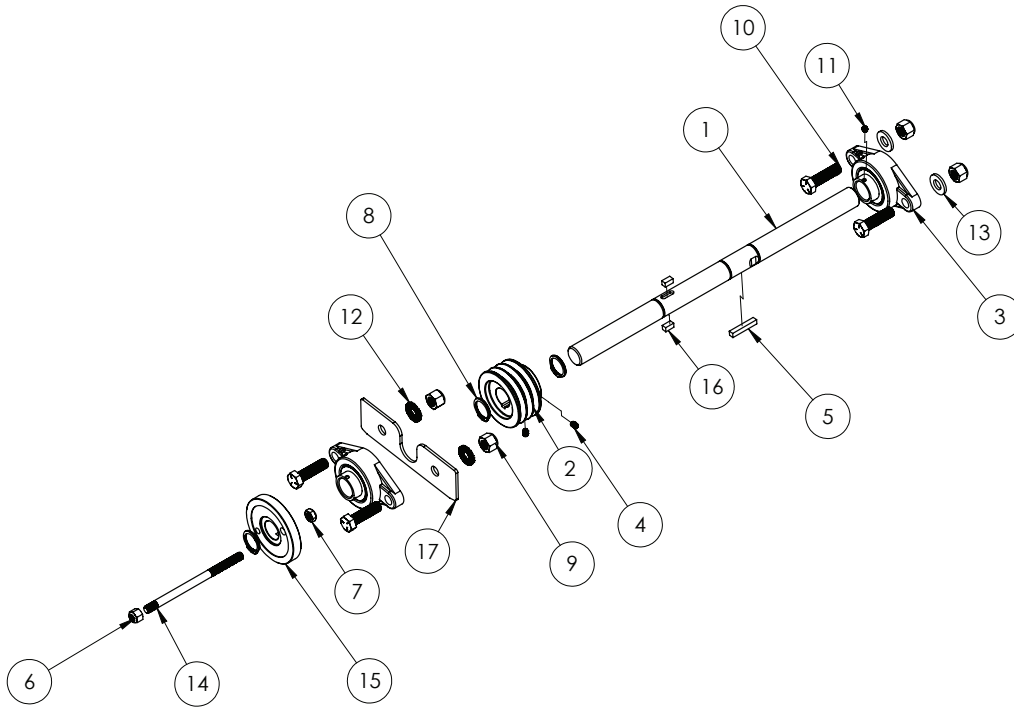

ITEM	QUANTITY	PART NUMBER	DESCRIPTION
1	1	SX77054	JS SHAFT
2	1	SX50163	3VX SHAFT PULLEY
3	2	SX90177	FLANGE BEARING 2 BOLT 1" BORE
4	2	SX50250	1/4"-20X3/8" SOCKET SET SCREW
5	1	US31195	1/4 X 1/4 X 1-1/2" KEY
6	1	US31052-2	3/8"-16 NYLON LOCK NUT
7	1	US31052	3/8" LOCK NUT
8	3	US32102-15	HEAVY DUTY EXTERNAL RETAINING RING
9	4	US31351-1	1/2"-13 NYLOCK NUT
10	4	US31222-7	MEDIUM-STRENGTH GRADE 5 STEEL HEX HEAD SCREW
11	2	US31093	1/4-20 X 1/4 KNURLED CUP SET SCREW
12	2	US31058-5	ZINC-FLAKE COATED STEEL WEDGE LOCK WASHER
13	2	US31351	WASHER, 1/2" FLAT SAE
14	1	US31172-3	BLACK-OXIDE STEEL SETUP STUD
15	1	SX80515	JS DRIVE FLANGE
16	2	US31195-3	MACHINE KEY
17	1	SX77139	JS BEARING FLANGE

Effective 10.1.2024. Machine built prior to this date may have different parts



# PARTS BREAKDOWN

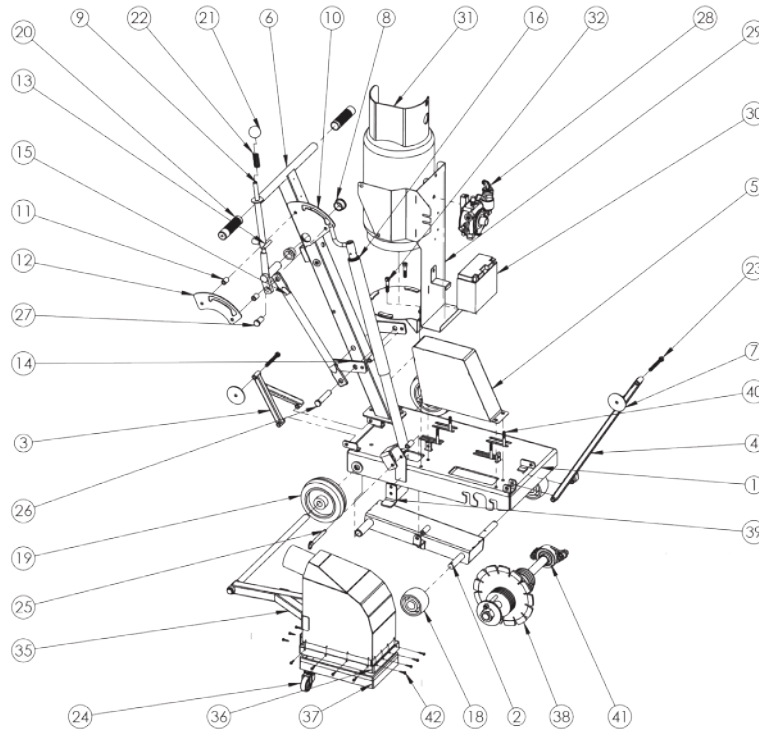

ITEM	QUANTITY	PART NUMBER	DESCRIPTION	ITEM	QUANTITY	PART NUMBER	DESCRIPTION
1	1	77120	MAIN CHASSIS	22	1	73706-1	LIFTING HANDLE SPRING
2	1	77127	FRONT AXEL ASSEMBLY	23	2	31167	POINTER WHEEL BOLT, 3/8"-16 x 3"
3	1	77116	POINTER ARM, 7"	24	1	60184	LOW PROFILE CASTER
4	1	78116	POINTER ARM, 24"	25	1	77158	BLADE GUARD LOCK PIN
5	1	77136R	JS BELT GUARD	26	1	77026	LIFTING MACHANISM CLEVIS PIN, LONG
6	1	77141	UPRIGHT HANDLE	27	1	77027	LIFTING MECHANISM CLEVIS PIN, SHORT
7	2	78119	POINTER WHEEL	28	1	SXVG479FC	FUEL CONVERSION KIT
8	2	2938T25	HANDLE BUSHING, 1" DIA	29	1	77172-1	PROPANE TANK HOLDER
9	1	77037	LIFTING HANDLE	30	1	77063	MC800P 12V BATTERY
10	1	90160-2	INNER DEPTH ADJUSTMENT QUADRANT	31	1	PRK10060	14LB PROPANE TANK
11	2	90160-4R	QUADRANT SPACER	32	1	31156-1	TANK BRACKET BOLT, 3/8"-16 x 1 3/4"
12	1	90160-3	OUTER DEPTH ADJUSTMENT QUADRANT	33	1	77164	JS BELT TENSIONER BRACKET
13	1	77030	DEPTH HANDLE LOCK	34	1	77166	JS BELT TENSIONER
14	2	77036	LIFTING MECHANISM BRACKET	35	1	77225	MC800P BLADE GUARD
15	1	77038-1	JS LIFTING MECHANISM PUSH ROD	36	1	SX77228	SKIRT STRIP, MC800P BLADE GUARD
16	1	77162	JS JACK ASSEMBLY	37	1	77226	MC800P POLYURETHANE SKIRT
17	1	SX80501	JS OUTER FLANGE	38	1	DCB08150U05S-JS	8 INCH WC BLADE
18	2	SX77021	FRONT AXLE PLASTIC WHEEL	39	1	77220-21	CHASSIS GUARD STOP
19	2	30042	MAIN CHASIS WHEEL	40	4	31114-5	MC800P ENGINE MOUNT BOLTS, 5/16"-24 x 2 1/4"
20	2	32404	RIBBED HANDLE GRIP, 1"	41	1	SX77009	MC800P SHAFT ASSEMBLY
21	1	90193	LIFTING HANDLE KNOB	42	12	US31122	#8 - 3/4", EXTERNAL HEX SHEET-METAL SCREW
*	1	SX50175	3/3VX300 Belt, Triple wide belt				



# PARTS BREAKDOWN

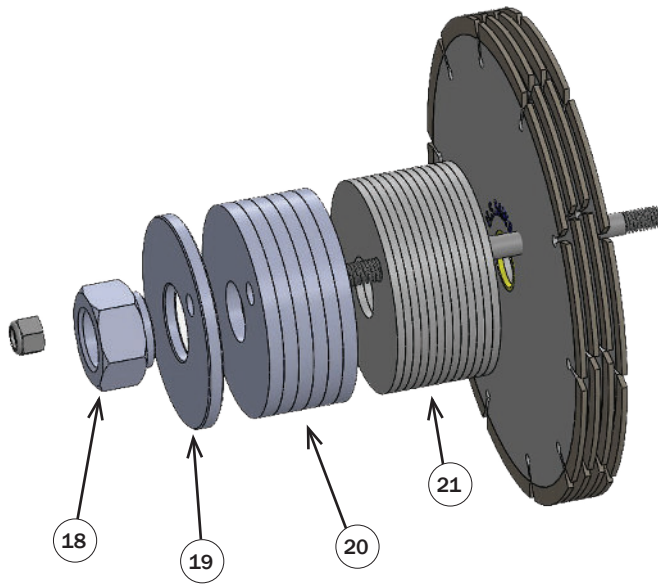

ITEM	QUANTITY	PART NUMBER	DESCRIPTION
18	1	SX80504	JS BLADE NUT
19	1	SX80512	JOINT HOG OUTER FLANGE
20	8	SX80502	JS BLADE SPACER .250
21	16	SX80506	JS BLADE SPACER .135



# MAINTENANCE AND INSPECTION

## 7.0 MAINTENANCE AND INSPECTION



**WARNING:** Release or disengage the turn the Vanguard engine switch to the OFF position, and turn the fuel valve lever to the OFF position before performing any maintenance and inspection. This will be referred to as the MC-800 OFF position in sections 7.1 through 7.7.



**WARNING:** Damaged diamond blades are hazardous and should never be used on a MC-800. Inspect diamond blades at least twice daily and before each use for signs of damage.



### TO AVOID INJURY.

Always inspect saw blades before use. Replace all cracked or damaged blades.

Figure 17 - Warning label - inspect blades before use



**CAUTION:** Running the MC-800 generates heat in the engine muffler, blade and blade guard. Do not touch these components without proper heat protecting work gloves.

### 7.1 Removing and installing the blade

**7.1.1** With engine in the OFF position, loosen the clamping knob and remove both 1-1/2" blade change wrenches from the MC-800 handle.

**7.1.2** Remove bolt in the blade guard holding bracket. Hold the blade guard firmly and raise guard up into the holding bracket. Reinsert bolt in the blade guard holding bracket and tighten nut.

**7.1.3** Place one wrench on the drive flange to hold the blade shaft in place. Place the other wrench on the blade nut and turn counter-clockwise to loosen the nut.

**7.1.4** Unscrew the blade nut. Slide the outer flange, spacers and blade off the shaft.

**7.1.5** Replace blade, spacers, and outer flange. Outer flange pin must line up with all spacers and drive flange to fit through properly.



**WARNING:** Be sure that the flanges, spacers, and blade are clean and undamaged before mounting. Do not use damaged parts. The MC-800 maximum blade operating speed is 5850 rpm as labeled on the blade guard. The MC-800 shaft diameter is 1 inch. Therefore, only use dry cut diamond blades rated for higher than 5850 rpm maximum safe speed and designed for 1-inch diameter shafts. Using a non dry cut diamond blade or a blade rated below 5850 rpm could result in severe blade failure, personal injury or death. Never cut material for which the blade was not designed. Check blade manufacturer's guidelines on material to be cut. Never operate a blade in the wrong rotation direction. Verify blade direction when changing blades.

## 5850 RPM

Figure 28 - Max RPM label - maximum blade speed



Use only diamond blades (steel centered diamond cutting-off wheels) with this machine. RPM rating on blade must exceed machine max rpm rating. The use of any other blade could result in death or serious injury.

2 Hazard Communication Systems, LLC  
800-746-0241

Reorder No. HSOU-369WHL

Figure 29 - Warning label - use only diamond blades

Figure 19 - Warning label - use only diamond blades

### 7.1.6 Spacers can be removed to allow room for the blade thickness.

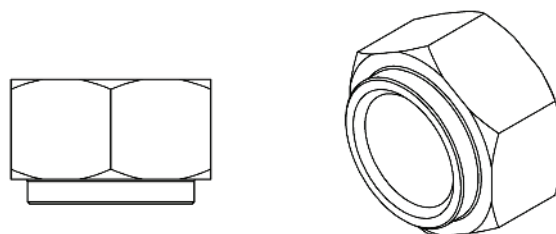

Figure 20 - Blade nut face must be flat against outer flange

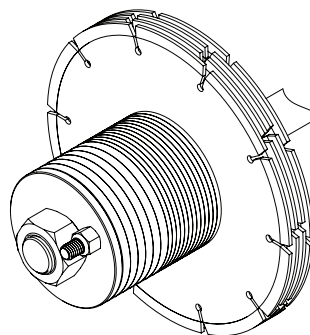
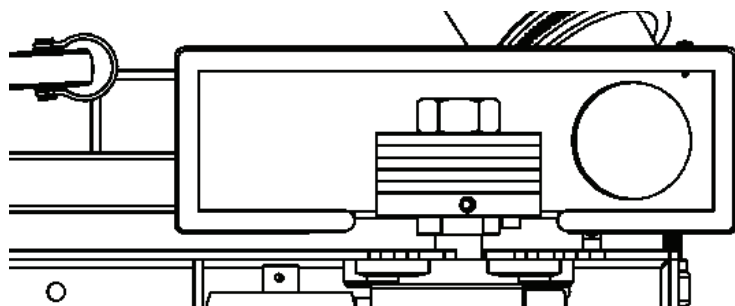

Figure 21 - JS Shaft Thread Length

1. When clamping nut, make sure there are only two threads or less exposed at end of shaft
2. Tighten large nut first
3. Tighten 3/8" stud nut



# MAINTENANCE AND INSPECTION



**Figure 21** - Blade, spacers, and flanges set up  
(Note: Shown with one spacer removed)

**7.1.7** Screw on and tighten the blade nut with wrenches making sure the face is flat against the outer flange. The blade shaft should be flush or slightly stick out beyond the blade nut to ensure all the blade nut threads are engaged. The outer flange pin should not touch the MC-800 chassis and 1/2" hex bolts when rotating. Rotate blade by hand to verify proper clearance and that the blade runs true (without wobbling). See Figure 30 and Figure 31. Never use a blade with interference or that does not run true.

**7.1.8** Lift up on blade guard and remove bolt in blade guard holding bracket. Lower the blade guard down. Reinsert bolt and tighten nut to prevent vibration. Always run a MC-800 with the blade guard in the down position.



**WARNING:** Breathable silica may be generated by use of this product; Silica can cause severe and permanent lung damage, cancer, and other serious diseases. Do not breathe the dust. Do not rely on your sight or smell to determine if the dust is in the air. Silica may be in the air without a visible dust cloud. If air monitoring equipment for silica is not provided by your employer at your work site, you **MUST** wear appropriate respiratory protection when using or servicing the machine. Consult your employer and OSHA regarding the appropriate respiratory protection.

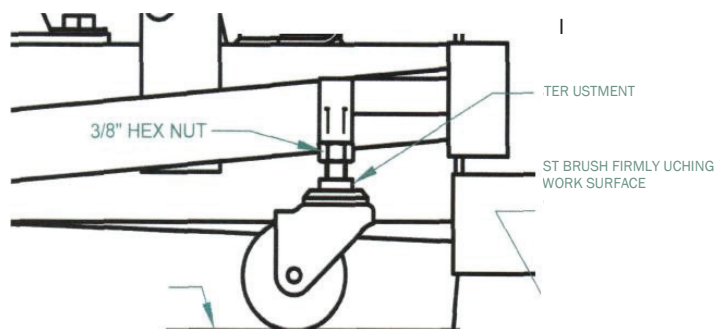

**Figure 22** - Blade guard caster wheel adjustment

**7.2.3** With the dust brush in the desired position, tighten the 3/8-inch hex nut by turning it counterclockwise.

## **7.3 Checking and adjusting belt tension**

**7.3.1** The belt tension should be checked after the first hour of operation on a new MC-800 or new belt. On a used MC-800, the belt tension should be checked once a day. With engine in the OFF position, remove the four 5/16" hex bolts that attach the belt guard to the chassis.

**7.3.2** Remove the belt guard. The belt should deflect no more than 1/16" under moderate finger pressure equidistant between the sheaves.

**7.3.3** To tighten the belt, loosen the four 5/16" hex nuts that hold the Vanguard engine to the chassis. Then, turn the 3/8" hex head bolt clockwise on the front of the MC-800. This bolt can be seen as item #44 in Figure 18.

**7.3.4** After reaching the desired belt tension, verify that the belt sheaves are properly aligned and the belt is straight. Retighten the four 5/16" hex nuts that hold the engine against the chassis.

**7.3.5** Replace the belt guard with the four 5/16" hex bolts that were removed in step 7.3.1. Never run a MC-800 without the belt guard in place.

## **7.4 Bearing lubrication**

**7.4.1** With engine in the OFF position, slowly tilt the MC-800 back until the handle rests on the ground.

**7.4.2** These bearings are exposed to excessive dust and require the same brand of high quality grease as supplied by the factory. Apply ALVANIA® Grease 3 with a hand grease gun to both flanged bearings on the blade shaft after every 100 hours of use.

**7.4.3** The performance of the bearing is greatly influenced by the quantity of grease. For optimum performance, insert grease until a little bleeds out from between the outer ring raceway and the perimeter of the slinger. Wipe off excess grease.

**7.4.4** Slowly tilt the MC-800 forward until all wheels are back on the work surface.

## **7.5 Vanguard engine maintenance**

**7.5.1** See the section titled "Servicing your Vanguard engine" in the Vanguard Engines Owner's Manual. This section includes detailed information on:

- 7.5.1.1** The importance of maintenance
- 7.5.1.2** Maintenance safety and precautions
- 7.5.1.3** Maintenance schedule
- 7.5.1.4** Refueling
- 7.5.1.5** Engine oil level check, oil change, and recommendations
- 7.5.1.6** Air filter inspection
- 7.5.1.7** Air cleaner service
- 7.5.1.8** Sediment cup cleaning
- 7.5.1.9** Spark plug service
- 7.5.1.10** Idle speed adjustment

## **7.6 Transportation**

**7.6.1** Allow the MC-800 blade guard, blade, engine, and engine muffler to cool.

**7.6.2** See the section titled "Helpful tips and suggestions - Transporting" in the Vanguard Engines Owner's Manual.

**7.6.3** With engine in the OFF position, securely strap down MC-800 to shipping pallet, trailer bed, etc. in normal upright position.

## **7.7 Trouble shooting**

**7.7.1** See the three sections titled "Helpful tips and suggestions, Taking care of unexpected problems, and Technical and consumer information" in the Vanguard Engines Owner's Manual.

**7.7.2** See Rx for Diamond Blade Safety by the Masonry and Concrete Saw Manufacturers Institute for diamond blade





# PROPANE POWER SYSTEM

**8.0 Read this Operation, Safety, and Maintenance Manual carefully. Be familiar with the controls and the proper use of the equipment.**

## 8.1 PREPARATION – BEFORE EACH USE:

- Do not operate and or store equipment or replacement cylinder(s) near sources of heat, open flames or sources of ignition, including cigarettes.
- Check for fuel leaks prior to operating the store equipment, utilizing leak detecting soap.
- Propane-Gas Cylinder and fuel system are under pressure. Avoid damage to these components that could result in fuel leaks.
- Close fuel cylinder service valve(s) when the equipment is not in use or when transporting the equipment.
- Do not operate or store equipment in an unventilated area.
- This equipment has been converted to operate on Propane-Gas fuel and may perform or handle differently than as originally manufactured.
- For additional information, read and follow all on-product warning labels provided by Propane Power Systems and your Propane-Gas supplier.
- Replace faulty mufflers

## 8.2 OPERATION:

- Never operate the machine with defective guards or shields, or without safety protective devices in place.

## 8.3 INSTRUCTION & SAFETY DECALS:

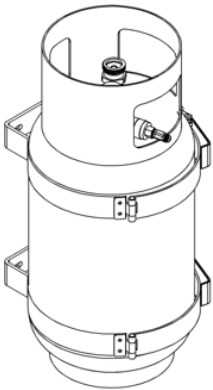

The fuel conversion for the Briggs & Stratton 627cc-Propane Powered System engine must use special vapor tanks that are specifically designed for vapor run small engine applications for concrete equipment. These tanks are available thru your local propane distributor/company or PPS.

## RPS150034



1. Propane Tank Specification
2. Use Propane Powered Systems Approved Tank Only
3. Mounting: Vertical
4. Quick Disconnect Valve: RH ACME Thread
5. Capacity: **33.5 LB -ONLY FILL TO 80% (26.8 LB)-**
6. Fuel Withdraw: Vapor

## RPS150035

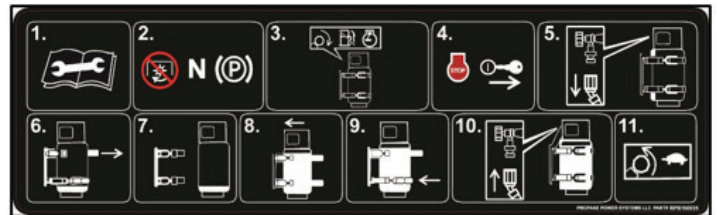

1. Familiarize yourself with the instructions listed below.
2. Stop the equipment on a flat surface, do not turn off engine, place transmission into neutral and engage the parking break.
3. Close the fuel valve on the propane tank by rotating clockwise; continue to run the engine.
4. When the engine shuts off, from the lack of propane fuel, turn the key to the off position and then remove the key.
5. Disconnect the ACME right hand thread connector from the propane tank.
6. Unlatch the two tank traps from the propane tank.
7. Remove the empty propane tank and inspect tank. Make sure both the fill valve and service valve are clean of debris.
8. Install the filled propane tank.
9. Latch the two tank straps onto the propane tank; make sure the propane tank is securely fastened to the tank straps.
10. Reconnect the ACME right hand thread connector to the service valve on the propane tank.
11. Slowly open the propane service valve counter-clockwise to equalize the pressure, check for leaks.



# PROPANE POWER SYSTEM

RPS150036



1. Danger – Propane fuel is extremely flammable and vapors are explosive.
2. Read the Operator's Manual. See NFPA 58: Liquefied Petroleum Gas Code for additional safety information.
3. Do not smoke or replace the tank around any sources of ignition.
4. Do not attempt or modify the tank or its components. Use only propane tanks approved by Propane Power Systems, LLC.
5. Close the fuel valve when the equipment is not in use, in storage or transporting.
6. Avoid contact with the propane fuel. Escaping vapors and liquids freeze skin on contact.

## 8.4 BEFORE OPERATION SAFETY

### FUEL SAFETY

- Propane tanks should be filled by trained and qualified personnel only.
- Do not change the tank when the engine is running.
- Never tamper with or repair tanks; contact trained and qualified personnel only.
- Before disconnecting the fuel hose, close the fuel valve on the tank and allow the engine to run until it stops to purge all of the propane vapors from the system.
- Do not operate the machine without the entire exhaust system in place and in proper working condition.
- Propane is heavier than air and may accumulate in low lying areas.
- To avoid personal injury or property damage, use extreme care in handling propane fuel. Fuel vapors are flammable and explosive.
- Never smoke around propane fuel tanks and stay away from an open flame or where fumes may be ignited by a spark.
- Extinguish all sources of spark or flame when approaching propane tanks or the equipment.
- Store the tank(s) away from heat, sparks or open flames.

### TYPE OF FUEL: HD5 GRADE PROPANE



Caution – Using overfilled tanks will result in damage to the fuel system regulator.

NEVER USE PROPANE TANKS THAT ARE FILLED BEYOND 80% CAPACITY



Propane Service Valve on Vapor Port

Fill Valve on Liquid Port

## FILLING PROPANE TANKS



Danger – Use extreme caution when handling propane. Propane is flammable and explosive and can cause personal injury if not handled properly.

No smoking or open flame around propane.

Fill the propane tank outdoors in a well-ventilated area.

Storage locations and trailers should be equipped with at least 1 approved portable fire extinguisher that has a minimum capacity of 18 lbs dry chemical with a B:C rating. Do not use carbon-tetrachloride extinguishers such as Pyrene.

- The propane tank must be removed from the equipment for filling.
- Only use propane when operating this machine. Never use any other type of fuel including diesel or methanol as serious damage in the engine will occur.
- The Briggs & Stratton 570cc Propane Power System engine must use special vapor tanks that are specifically designed for vapor run small engine applications.
- Turn off the service valve, unscrew the ACME left hand thread connector and unlatch the propane tank straps.
- Remove the tank from the equipment.
- The tank must be filled by a trained propane filling station attendant or have been officially trained by a propane fuel provider.
- The propane information in this Operator's Manual is provided only as a guide. Consult the NFPA 58: Liquefied Petroleum Gas Code, 2008 Edition for additional safety information. The National Fire Protection Association (NFPA) code pertain to the handling, storing, transporting and usage of propane fuel.



# PROPANE POWER SYSTEM

## 8.4 Operational Set Up

### Engine Oil Level & Adding Oil

Oil Capacity = 46 – 48 fl oz

- The engine(s) are tested and set at the factory. Then the oil is drained for shipment.

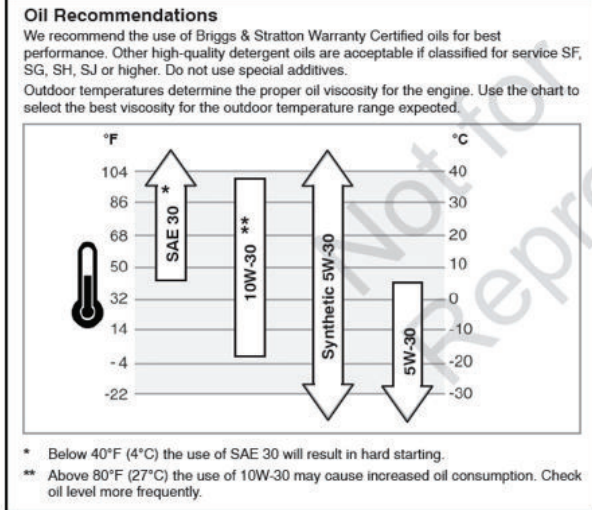

Figure - 1

- PPS recommends the use of Synthetic 5W-30. Better for engine brake in period and longer duration between oil changes

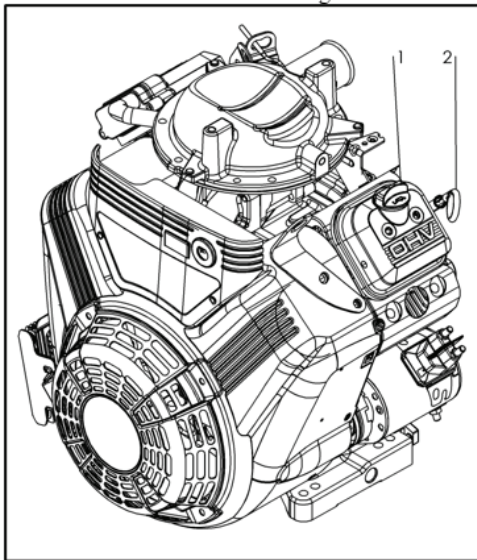

Figure - 2

- Remove the (1) filler cap and slowly add approximately 80% of the specified oil and slowly add the additional oil to bring the level of oil to the full mark on the (2) dipstick (Figure-2).

### Familiarization of Vertical Propane Vapor Tank

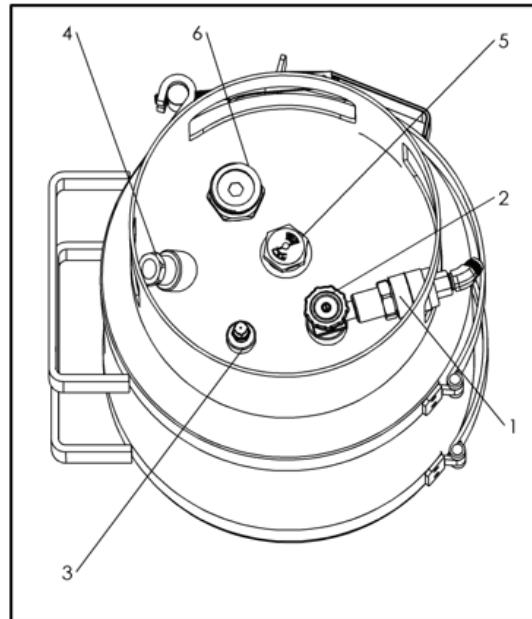

Figure - 3

- The equipment operators need to familiarize themselves with the connections, valves and gauges on the propane tanks.
- Figure -3 identifies the connections, valves and gauges as the following:
  1. Quick Disconnect Right Hand ACME Thread Valve.
  2. Vapor Tank Service Valve.
  3. Bleeder Valve (Only to be used by trained and qualified personnel. The bleeder valve is used during the propane fill process).
  4. Safety – Pressure Relief Valve
  5. Propane – Fuel Gauge
  6. Fill Valve (Only to be used by trained and qualified personnel).



# WARRANTY AND SERVICE

## 8.0 WARRANTY AND SERVICE

### 8.1.1 Warranty

This document is to be used as a guide in determining warranty policies and procedures for U.S.SAWS and its U.S.SAWS products. It is to be used in determining whether a warranty is justified and as a procedural guide in completing a U.S.SAWS warranty claim form.

### 8.1.2 Warranty Responsibility

The distributor or the end user must prepare a Machine Warranty Information Card when the machine is delivered. Failure to comply will make any and all warranties on this equipment null and void. Credit for warranty repairs will be given only after receipt of the WARRANTY CLAIM FORM, properly completed with all the required details. Submittal details are described later in this document.

### 8.1.3 Warranty Policy

**8.1.3.1** U.S.SAWS warrants its U.S.SAWS products against defects in material and workmanship under normal and proper use for a period of one year (365) days from the date of delivery; in the case of Rental Fleet Machines, date of assignment to Rental Fleet. Such warranty is extended only to the buyer who purchases the equipment directly from U.S.SAWS or its authorized distributor. This warranty does not include expendable parts such as, but not limited to, plugs, cutters, blades, blast wheel, wear parts, liners and seals.

**8.1.3.2** The obligation under this warranty is strictly limited to the replacement or repair, at US SAWS's option, of machines and does not include the cost of transportation, loss of operating time, or normal maintenance services.

**8.1.3.3** This warranty does not apply to failure occurring as a result of abuse, misuse, negligence, corrosion, erosion, normal wear and tear, alterations or modifications made to the machine without express written consent of U.S.SAWS .

**8.1.3.4** Warranty request must be submitted in writing within thirty (30) days after failure.

**8.1.3.5** Written authorization to return merchandise under warranty must first be obtained from U.S.SAWS .

**8.1.3.6** U.S.SAWS reserves the right to inspect and make the final decision on any merchandise returned under warranty.

**8.1.3.7** U.S.SAWS offers no warranty with respect to accessories, including but not limited to, engines, motors, batteries, electrical boards, tires and any other parts not manufactured by us but which the original manufacturer warrants.

**8.1.3.8** U.S.SAWS reserves the right to make product changes or improvements without prior notice and without imposing any obligation upon itself to install the same on its products previously sold.

**8.1.3.9** The above warranty conditions can only be altered by U.S.SAWS. U.S.SAWS must confirm alterations in writing for each specific transaction.

**8.1.3.10** U.S.SAWS reserves the right to establish specific warranty terms for used or demo machines on an individual transaction basis. Invoices covering such merchandise will clearly state the provisions of the applicable warranty for each specific transaction.

**8.1.3.11** WE DO NOT AUTHORIZE ANY PERSON, REPRESENTATIVE OR SERVICE OR SALES ORGANIZATION TO MAKE ANY OTHER WARRANTY OR TO ASSUME FOR US ANY LIABILITY IN CONNECTION WITH THE SALE OF OUR PRODUCTS OTHER THAN THOSE CONTAINED HEREIN.

**8.1.3.12** UNDER NO CIRCUMSTANCES SHALL US SAWS BE LIABLE TO CUSTOMER OR ANY OTHER PERSON FOR ANY DIRECT, INCIDENTAL, OR CONSEQUENTIAL DAMAGES RESULTING FROM THE USE OF THE PRODUCT OR ARISING OUT OF ANY BREACH OF ANY WARRANTY OR FOR ANY SPECIAL OR CONSEQUENTIAL DAMAGES OF ANY CHARACTER, INCLUDING WITHOUT LIMITATIONS, DAMAGES FOR ANY LOSS OF GOODWILL, WORK STOPPAGE, OR ANY AND ALL OTHER COMMERCIAL DAMAGES OR LOSSES.

**8.1.3.13** U.S.SAWS MAKES NO OTHER WARRANTIES, EXPRESSED OR IMPLIED, INCLUDING, BUT NOT LIMITED TO, THE IMPLIED WARRANTIES OF MERCHANTABILITY AND FITNESS FOR A PARTICULAR PURPOSE WITH RESPECT TO THE US SAWS PRODUCTS SOLD PURSUANT THERETO.



# MACHINE WARRANTY INFORMATION CARD

**TO ENSURE THE PROPER WARRANTY COVERAGE IS EXTENDED TO THE OWNER OF THIS MACHINE, FILL OUT THE ATTACHED CARD COMPLETELY AND ACCURATELY.**

## **WARRANTY REGISTRATION CARD**

IMPORTANT! To ensure that your U.S.SAWS machine is covered under warranty, please fill in the following information and mail or fax it to U.S.SAWS, 8004B E. Broadway Ave. Tampa, FL 33619 Fax No. (813) 621-7125.

<b>COMPANY</b>
<b>NAME</b>
<b>ADDRESS</b>
<b>INTENDED USE</b>
<b>DATE OF PURCHASE</b>
<b>INTENDED USE</b>
<b>SERIAL NUMBER</b>

If you are not the owner of record as shown on the manual copy of the warranty registration card, do not operate this machine before contacting U.S.SAWS at 1-877-817-6687. Verify the following before operating the equipment:

## **CHANGE OF OWNER OR NEW ADDRESS REGISTRATION CARD**

IMPORTANT! To ensure that your U.S.SAWS machine is covered under warranty, please fill in the following information and mail or fax it to U.S. SAWS, 8004B E. Broadway Ave. Tampa, FL 33619, Fax No. (813) 621-7125.

<b>COMPANY</b>
<b>NAME</b>
<b>ADDRESS</b>
<b>INTENDED USE</b>
<b>DATE OF PURCHASE</b>
<b>INTENDED USE</b>
<b>SERIAL NUMBER</b>

21



**SURFACE PREP  
DIVISION**

877-817- 6687  
Visit us at [www.ussaws.com](http://www.ussaws.com)  
[sales@ussaws.com](mailto:sales@ussaws.com)

