

U.S.SAWS™

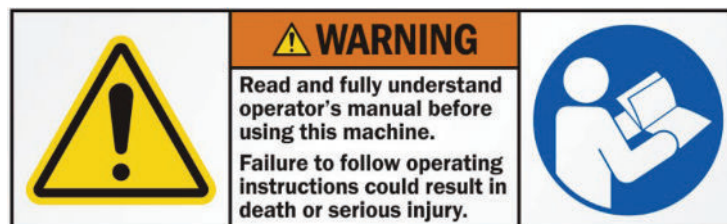

U.S.SAWS MC-1000 OPERATING MANUAL



Notice of Copyright Protection

Copyright 2020, by U.S.SAWS . All rights reserved. This work may not be reproduced or disseminated in whole or in part by any means without the prior written permission of U.S.SAWS

3-26-2026

U.S.SAWS™

**SURFACE PREP
DIVISION**

P: 877-817- 6687
Visit us at www.ussaws.com
sales@ussaws.com



INTRODUCTION & SPECIFICATIONS

1.0 INSTRUCTIONS FOR USE OF MANUAL SECTIONS

Section	Page
Table of Contents & Introduction	2
Symbols & Decals	3
Safety Instruction	4 - 5
Pre-Operation Checklist	6 - 8
Operation	9 - 10
Parts Breakdown	11 - 13
Maintenance & Inspection	14 - 15
Propane Power System	16-19
Warranty & Service	20

Foreword/Introduction

The MC-1000 is a Certified Propane Powered, self propelled, Joint Clean-out Saw/Mill designed to clean-out existing control joints to prepare for new joint fill applications or remove failing or deteriorated existing joint fill material. This machine can be used to remove polyurea, epoxy, and polyurethane joint fill materials. This machine is designed for large joint clean-out projects where a certified propane power source is preferred over gas or electric.

The 23 HP Briggs and Stratton Vanguard V-Twin, a certified propane engine, powers the saw. It features an electric start, and the twin-cylinder design has reduced vibration and high torque.

Features:

- Can hold up to 16 blades for a cutting width of 4"
- Equipped with a CO monitor
- Up cut blade rotation removes debris and material from the joint and ejects it up towards the vacuum port
- Versatile blade configurations provide solutions for joint clean-out and spalled joint restoration
- Redesigned belt drive system for easier maintenance and longer wear life
- Front and rear pointer guides for accuracy

Read this entire operations and maintenance manual before using your new tool. Pay close attention to the Rules for safer operation,

Dangers, Warnings and Cautions.

The purpose of safety symbols and explanations are to attract your attention to possible hazards and how to avoid them. The safety symbols and explanations do not by themselves eliminate any danger. The instructions or warnings they give are not substitutes for proper accident prevention measures.



DANGER: Indicates an imminently hazardous situation that if not avoided, will result in death or serious injury. This signal word is limited to the most extreme situations.



WARNING: Indicates a potentially hazardous situation that, if not avoided, could result in death or serious injury.



CAUTION: Indicates a potentially hazardous situation that, if not avoided may result in minor or moderate injury. It may also be used to alert against unsafe practices that may cause property damage.

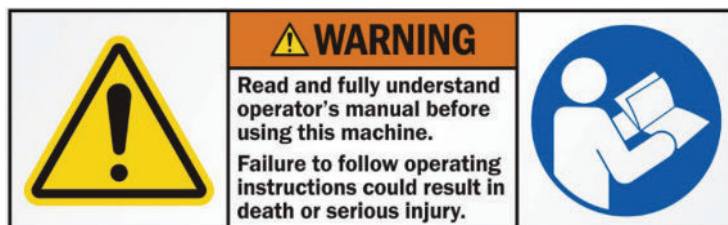

2.0 SPECIFICATIONS

MC-1000 SPECIFICATIONS	
Part Number	SX78200
Fuel Type	Vapor Propane
Engine/ Tank	23 HP Briggs
Max Cutting Depth	3"
Max Cutting Width	4"
Arbor	1" with DPH
Blade Size	8" to 10"
Blade Width	.150" and standard options
Dust Collector Size	350+ CFM
Weight	700



SYMBOLS & DECALS

3.0 SYMBOLS & DECALS

For Safe Operation

You must be qualified for safe operation of the U.S.SAWS MC-1000 machine. You must clearly understand the written instructions supplied by U.S.SAWS, be trained - including actual operation - & know the safety rules & regulations for the job site. It is a safety practice to point out & explain safety signs & practices to others & to make sure they understand the importance of following these instructions.

Be Safe

Human error is the result of many factors: carelessness, fatigue, sensory overload, preoccupation, unfamiliarity with the machine or attachments, or drugs or alcohol, to name a few. You can avoid serious injury or death caused by these & other unsafe work practices. Be safe and never assume accidents cannot happen to you.

For your safety and the safety of others, act safely and encourage your fellow workers to act safely as well.



Read and understand operator's manual before using this machine. Failure to follow operating Instructions could result in injury or damage to equipment.



Use only diamond blades (steel centered diamond cutting-off wheels) with this machine. RPM rating on blade must exceed machine max rpm rating. The use of any other blade could result in death or serious injury.

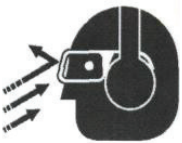

Flying debris and loud noise hazards. Wear ear and eye protection



Engine exhaust contains poisonous carbon monoxide gas. Breathing it could cause death. Operate machine in well ventilated area.

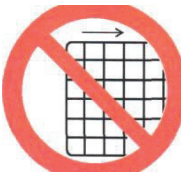

AVOID INJURY.

Do NOT operate with guard removed. Replace guard before operating machine.



Wear safety boots when operating this machine



Wear appropriate clothing



Wear Head Protection, breathing protection, and the use of hearing protection is mandatory



Wear hand protection



Wear proper electrostatic grounding equipment at all times. Static discharge during fueling can cause explosion

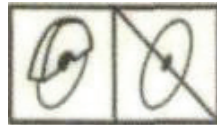

Keep all guards in place



Rotating blade hazard. Do NOT operate with guard up. Keep hands and feet away.



TO AVOID INJURY.

Always inspect saw blades before use. Replace all cracked or damaged blades.



SAFETY INSTRUCTIONS

4.0 SAFETY INSTRUCTIONS

4.1 KNOW THE RULES & YOUR EQUIPMENT.

Most job sites have rules governing equipment use & maintenance. Before starting at a new work location, check with the supervisor or safety coordinator. Ask about any rules or regulations you need to abide.

OSHA enforces federal laws within the United States that apply to the safe operation, application, & maintenance of equipment on job sites. It is the employer's responsibility to comply with these laws.

Do not operate this machine unless you have read the operations and maintenance manual carefully. Read any additional instructions included from other manufacturers and organizations such as Vanguard and the Masonry and Concrete Saw Manufacturers Institute. Learn the applications and limitations as well as the specific potential hazards related to this tool

4.2 RECEIVE PROPER TRAINING.

Do not operate this machine unless you have received operational and maintenance training from a U.S. SAWS representative or from an authorized distributor for U.S.SAWS.

4.3 PROTECT YOUR FEET.

Observe all applicable local, state and federal safety regulations. Wear OSHA approved foot protection.

4.4 PROTECT YOUR EYES.

Observe all applicable local, state and federal safety regulations. Wear OSHA approved safety glasses.

4.5 PROTECT YOUR LUNGS.

Breathable silica may be generated by use of this product. Silica can cause severe and permanent lung damage, cancer, and other serious diseases. Do not breathe the dust. Do not rely on your sight or smell to determine if the dust is in the air. Silica may be in the air without a visible dust cloud. If air monitoring equipment for silica is not provided by your employer at your work site, you **MUST** wear appropriate respiratory protection when using or servicing the machine. Consult your employer and OSHA regarding the appropriate respiratory protection.

4.6 PROTECT YOUR HEARING.

Observe all applicable local, state and federal safety regulations. Wear OSHA approved hearing protection.

4.7 DRESS PROPERLY.

Do not wear loose clothing or jewelry that can be caught in moving parts. Wear protective hair covering to contain long hair. Keep hair away from motor air vent. Rubber gloves and non-skid footwear are recommended when working outdoors

4.8 AVOID A DANGEROUS ENVIRONMENT.

Do not expose machine to rain. Do not use machine in wet conditions. Keep work area well lit. When working at an elevated location, pay attention to articles and persons below.

4.9 BEWARE OF HIDDEN DANGERS IN CONCRETE.

Rebar or utility lines may be buried in concrete. Disconnect the power to any utility lines. If these items are to be missed, clearly mark the area. If these items are to be cut, check the blade manufacturer's guidelines on material to be cut.

4.10 AVOID ANY AREAS OR ACTIONS THAT EXPOSE YOU TO CARBON MONOXIDE.

Exhaust gas from gasoline engines contains dangerous carbon monoxide. Breathing it can cause unconsciousness and even kill you. Always operate gasoline engine machines in a well-ventilated area. Do not operate in areas where exhaust fumes could accumulate without wearing appropriate respiratory protection. Consult your employer and OSHA

regarding use of appropriate respirator for dangerous carbon monoxide gases.

4.11 KEEP WORK AREA CLEAN. DO NOT RUN OVER ANYTHING.

Loose objects could be thrown from crack. Make sure area to be cut is clear from people and any loose objects, nuts, bolts, etc. Never run over any loose objects.

4.12 KEEP CHILDREN AND VISITORS AWAY.

Do not allow anyone to stand in line with the blade path. Do not let children or visitors contact machine or extension cord. Keep children and visitors away from the work area.

4.13 AVOID FLAMMABLE LIQUIDS OR GASES.

Engines and diamond blades produce heat and sparks during operation. Never use machines in dangerous sites containing flammable, combustible or explosive materials such as lacquer, paint, benzene, thinner, gasoline, gases, and adhesive agents.

4.14 AVOID CONTACT WITH HOT MUFFLER.

The muffler becomes hot during operation and remains hot after stopping the engine. Do not touch the muffler while it is hot. Let the engine cool before storing indoors. Do not place flammable objects close to the engine.

4.15 AVOID CONTACT WITH HOT BLADE AND BLADE GUARD.

The blade and blade guard become hot during operation and remain hot after stopping the engine. Do not touch the blade and blade guard without proper hand protection.

4.16 KEEP FIRM GRIP ON MACHINE.

During normal operation as instructed in Section 6.0, keep a firm hold on the handle grips and maintain control of the machine until the blade completely stops.

4.17 SHUT OFF ENGINE.

When not in use, before servicing and when changing accessories shut off engine. Release the lever switch and move the on/off switch to the OFF position. Move the fuel valve lever to the OFF position.

4.19 CHECK BLADE AND MACHINE ROTATION DIRECTION.

Never operate a blade in the wrong rotation direction. Check the machine rotation direction and blade direction when mounting a blade.

4.20 CHECK BLADE MAXIMUM ALLOWABLE SPEED.

Check the maximum operating speed of the machine and blade. Never use a blade rated less than the machine's maximum speed rating.

4.21 CHECK BLADE FOR CRACKS, DAMAGE, AND MISALIGNMENT.

Never use a cracked, damaged, or misaligned blade. After mounting blade, rotate by hand to check for proper alignment.

4.22 CHECK DIAMOND BLADE FOR WARNINGS.

Many diamond blades contain a chemical known to the state of California to cause cancer and/or birth defects or other reproductive harm. Diamond blades improperly used are dangerous. Comply with American National Standards Institute Safety Code B71 and Occupational Safety & Health Act covering SPEED, SAFETY GUARDS, FLANGES, MOUNTING PROCEDURES, GENERAL OPERATING RULES, HANDLING, STORAGE & INSPECTION AND GENERAL MACHINE CONDITIONS. Read Diamond Blades Safety Manual before use.

4.23 DO NOT FORCE WRONG SIZE OR TYPE BLADE ONTO MACHINE.

Do not force a blade onto the machine shaft or alter the size of the arbor-mounting hole. Be certain that the drive pin is in place through the blade when tightening the blade nut. Never add a drive pin hole or modify a blade.

4.24 USE CORRECT SAW AND ACCESSORIES.

Do not force a small saw to do the job of a heavy-duty saw. Do not use the saw for improper applications. Never cut material for which the blade was not designed. Check blade manufacturer's guidelines on material to be cut.



SAFETY INSTRUCTIONS

4.25 STORE IDLE EQUIPMENT.

The machine, blades and tools should be stored in a dry and secure location when not in use. Keep equipment out of reach of children.

4.26 DO NOT FORCE SAW.

The saw will do the job better and safer at the rate for which it was designed.

4.27 OBTAIN SAFETY DATA SHEET (SDS) FOR ALL WORK SURFACE MATERIALS.

This includes primers, all coatings, adhesives, tile and crack filling materials, etc. Do not attempt to cut, clean out or remove material without SDS information. Consult SDS sheet for hazards information. Be aware that some materials are explosive as a dust.

4.28 DO NOT OVERREACH.

Keep proper footing and balance at all times.

4.30 MAINTAIN MACHINE WITH CARE.

Keep machine clean and follow maintenance procedures for better and safer performance. Keep handles dry, clean, and free from oil and grease. Follow instructions for lubricating and changing accessories.

4.31 REMOVE ADJUSTING TOOLS.

Form a habit of checking to see that tools such as adjusting wrenches are removed from the machine and properly stored before starting the engine.

4.32 STAY ALERT.

Watch what you are doing. Use common sense. Do not operate machine when you are tired or fatigued.

4.33 DO NOT USE DRUGS, ALCOHOL, MEDICATION.

Do not operate machine while under the influence of drugs, alcohol, or any medication.

4.34 KEEP THE RIGHT PARTS IN THE RIGHT POSITIONS.

Do not operate machine with parts missing or improperly mounted.

4.35 CHECK DAMAGED PARTS.

Verify all machine guards are in good condition and will function properly before using the machine. Check for alignment of moving parts, binding of moving parts, breakage of parts, mounting, and any other conditions that may affect machine operation. A guard, power switch or other part that is damaged should be properly repaired or replaced by an authorized service center unless indicated elsewhere in this instruction manual. Do not operate machine if lever or engine on/off switch does not function properly.

4.36 SECURELY MOUNT ACCESSORIES AND BLADES TO THE MACHINE.

Extra care must be taken when using saws on an elevated location to prevent injury to someone on a lower level in the event the tool or accessory should drop. Do not operate without fall protection for operator and debris protection for public.

4.37 NEVER TOUCH THE MOVING PARTS.

Never touch moving parts such as blades, belts and others.

4.38 STOP OPERATION IMMEDIATELY IF ANY ABNORMALITY IS DETECTED.

Stop using machine immediately if any abnormalities are observed during operation. Examples of abnormalities include unusual noise and vibration.

4.39 WHEN REPLACING A PART, USE THE SAME TYPE AND QUALITY.

When replacing a component part with a new one, use only the same type and quality of new part. Never attempt to repair a machine if you are unfamiliar with proper procedures and techniques required.

4.40 NEVER DISABLE THE LEVER.

Do not modify, disable, or attempt to permanently engage the lever. Do not operate a machine if lever is not functioning. This could lead to serious injury or death.

4.41 LOAD AND UNLOAD SAFELY.

Use proper heavy lifting procedures. Read & understand manuals before loading & unloading.

4.42 STORAGE.

Always store equipment properly when it is not being used. Equipment should be stored in a clean, dry location and out of reach of children.

4.43 SAVE THESE INSTRUCTIONS.

Refer to this operations and maintenance manual as well as any additional instructions included from other manufacturers and organizations such as Vanguard and the Masonry and Concrete Saw Manufacturers Institute®. Never permit anyone to operate the machine without proper instructions.



DUST WARNING

Cutting, especially when DRY cutting, generates dust that comes from the material being cut, which frequently contains silica.

Silica is a basic component of sand, quartz, brick clay, granite and numerous other minerals and rocks. Exposure to excessive amount of such dust can cause:

- Respiratory diseases (affecting your ability to breath), including chronic bronchitis, silicosis and pulmonary fibrosis from exposure to silica. These diseases may be fatal;
- Skin irritation and rash; and
- Cancer according to NTP* and IARC*

* National Toxicology Program, International Agency for Research on Cancer

Take precautionary steps

- Avoid inhalation of and skin contact with dust, mist and fumes;
- Wet cut when feasible, to minimize dust;
- Wear and ensure that all bystanders wear appropriate respiratory protection such as dust masks designed to filter out microscopic particles. (See OSHA 29 CFR Part 1910.1200)

California Prop 65 Warning: Use of this product can cause exposure to materials known to the State of California to cause cancer and/or birth defects or other reproductive harm.



PRE-OPERATION CHECKLIST

5.0 PRE-OPERATION CHECKLIST



Read and understand operator's manual before using this machine. Failure to follow operating instructions could result in injury or damage to equipment.

Figure 1 - Warning label - read and understand manual

5.1 Start by reading the entire Vanguard Engines Owner's Manual, Rx for Diamond Blade Safety, and Rx for Concrete Saws by the Masonry and Concrete Saw Manufacturers Institute. Then, read the entire MC-1000 operations and maintenance manual. Get familiar with the machine's parts. See Figure 1 through Figure 32.

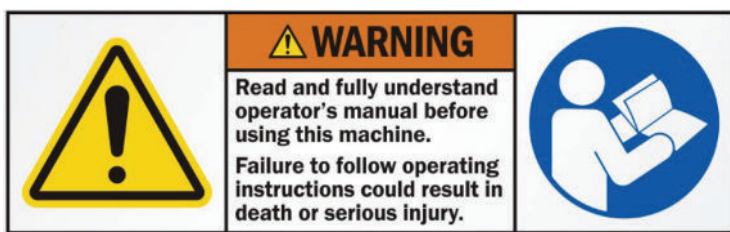

TO PREVENT SERIOUS INJURY DO NOT OPERATE SAW WITHOUT PROPER TRAINING AND UNDERSTANDING OF THE OWNERS MANUAL WHEN OPERATING THIS MACHINE

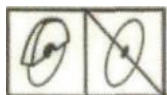

Keep all guards in place



Wear Head Protection, breathing protection, and the use of hearing protection is mandatory



Flying debris and loud noise hazards. Wear ear and eye protection



Wear hand protection



WARNING: Improperly maintaining the MC-1000 including the Vanguard engine or failing to correct a problem before operation could cause a malfunction resulting in a serious injury. Always perform a pre-operation inspection before each operation and correct any problem. See Vanguard Engines Owner's Manual.

5.2 Check the condition of the Vanguard engine. See the section titled "Before operation - is your engine ready to go?" in the Vanguard Engines Owner's Manual.



AVOID STATIC ELECTRICITY RISK

WARNING: Ultra-Low Sulfur Diesel (ULSD) presents an increased risk of static ignition. Always consult your propane supplier to ensure the fueling system meets proper grounding and bonding standards. To reduce the risk of static discharge, a grounding (discharge) strap must remain connected to all U.S.SAWS vacuum systems whenever the equipment is in use.



Wear proper electrostatic grounding equipment at all times. Static discharge during can cause explosion



WARNING: Exhaust gas engines contains dangerous carbon monoxide. Breathing it can cause unconsciousness and even kill you. Always operate in a well-ventilated area. Do not operate in areas where exhaust fumes could accumulate without wearing appropriate respiratory protection. Consult your employer and OSHA regarding use of appropriate respirator for dangerous carbon monoxide gases. See Figure 7.



Engine exhaust contains poisonous carbon monoxide gas. Breathing it could cause death. Operate machine in well ventilated area.

Figure 2 - Warning label - engine exhaust contains carbon monoxide gas 11

5.3 Observe the condition of your work environment. Walk over area work area and look for hazards. Make sure the work environment is safe and meets all safe-working conditions discussed in section 4, Rules for safer operation.

5.4 Obtain SAFETY DATA SHEET (SDS) for all work surface materials. This includes primers, all coatings, adhesives, tile and crack filling materials, etc. Do not attempt to cut, clean out, or remove material without SDS information. Consult SDS sheet for health hazards information. Be aware that some materials are explosive as a dust



WARNING: The MC-1000 maximum blade operating speed is 5,850 rpm as labeled on the blade guard. Use only dry cut diamond blades rated higher than 5,850 rpm safe operating speed. Do not use a blade rated for less than 5,850 rpm. Do not use a blade that is not a dry cut diamond blade. Using a non dry cut diamond blade or a blade rated below 5,850 rpm could result in severe blade failure, personal injury or death. See Figure 8 and Figure 9. Never cut material for which the blade was not designed. Check blade manufacturer's guidelines on material to be cut. Never operate a blade in the wrong rotation direction. Verify blade direction when changing blades. The MC-1000 is designed to cut in a straight line. Never attempt to cut any pattern or follow any joint that is not a straight line.



PRE-OPERATION CHECKLIST

5,850 MAX. RPM

Figure 3 - Max rpm label - maximum blade speed

5.5 Choose the proper dry cut diamond blade for the application, speed and material to be cut. See Figure 9.



Use only diamond blades (steel centered diamond cutting-off wheels) with this machine. RPM rating on blade must exceed machine max rpm rating. The use of any other blade could result in death or serious injury.

Figure 4 - Warning label - use only diamond blades

5.5 Clearly mark all intended cut areas with straight paint or chalk lines.

5.6 Verify that the travel lever is disengaged or released, and the Vanguard engine switch and fuel valve lever are in the OFF position. Make sure blade is completely stopped.



CAUTION: Running the MC-1000 generates heat in the engine, blade and blade guard. Do not touch these components without wearing proper heat protecting work gloves.

5.7 Hold the blade guard firmly and raise the guard up vertically.

5.8 Remove both blade change wrenches from the MC-1000 handle. Install dry cut diamond blade. Inspect diamond blades for damage at least twice daily and before each use. Damaged diamond blades are hazardous and should never be used on a MC-1000.



TO AVOID INJURY.

Always inspect saw blades before use. Replace all cracked or damaged blades.

Figure 5 - Warning label - inspect blades before use

5.9 Replace the wrenches in the holding bracket on the handle. Tighten the wrench-clamping knob.

5.10 Check the belt tension each day before starting work. Check after the first hour of operation if the MC-1000 or belt is new.

5.11 Move the front and rear pointer arms down towards the ground. Setting depth (depth lock) lower blades to ground with lift/lower control handle. When blades have touched rotate depth lock handle clockwise until it steps. This sets the lock handle at "0" depth. Each turn of depth lock handle counter clockwise will lower depth 1/4" (approximately)

5.12 Using the marked chalk line or any straight line on the ground, align the blade with the line. On the pointer wheels, loosen the adjustment nuts and align the wheels with the same chalk line. Push the MC-1000 along the line to verify the alignment is straight.



PRE-OPERATION CHECKLIST

CAUTION

CAUTION: The blade depth is approximate and not exact. Many variables affect the exact blade depth such as the exact diameter of a worn diamond blade. If an accurate depth must be cut, install the blade to be used with the engine in the OFF position. Place the MC-1000 in a secure position that allows the blade to overhang and be visibly measured at full blade depth. An example would be blocking the wheels with the engine in the OFF position and lowering the MC-1000 blade along side a street curb. This will allow a measurement from the bottom of the blade to the top of the curb.

5.14 Make sure the blade guard caster wheel and white dust urethane seal at the blade guard base are firmly touching the work surface.

WARNING

WARNING: Breathable silica may be generated by use of this product. Silica can cause severe and permanent lung damage, cancer, and other serious diseases. Do not breathe the dust. Do not rely on your sight or smell to determine if the dust is in the air. Silica may be in the air without a visible dust cloud. If air monitoring equipment for silica is not provided by your employer at your work site, you **MUST** wear appropriate respiratory protection when using or servicing the machine. Consult your employer and OSHA regarding the appropriate respiratory protection.

5.15 Slide the 3" diameter vacuum hose over the connector and tighten the worm drive hose clamp. Pull firmly on the hose to verify the connection will not slide off.

5.16 Check for missing or loose bolts. Tighten loose bolts and replace missing bolts before operating machine. Verify that belt and blade guards are in place. Never operate a MC-1000 without guards in place.

WARNING

5.17 **WARNING:** If you can see the drive belt or diamond blade, the guards are not in place. Never operate a MC-1000 without guards in place. The proper position for the belt guard is bolted with four bolts to the chassis. The proper position for the blade guard is down with the white guard dust brush touching the horizontal surface.

5.18 Dress properly. Wear ear and eye protection. See sections 4.3 through 4.7. See Figure 16

5.19 MC-1000 premium dry cut diamond blades, U.S.SAWS DCB10150U05-JS is the recommended blade for all applications.

WARNING

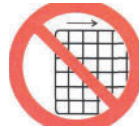

AVOID INJURY.
Do NOT operate with guard removed. Replace guard before operating machine.

Figure 8 - Warning label - do not operate with guard removed

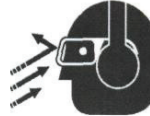

Flying debris and loud noise hazards. Wear ear and eye protection

Figure 10 - Warning label - wear proper clothing, ear and eye protection

WARNING

WARNING: Recommended accessories for this tool including blades are listed in this manual or are available by calling customer service. The use of any other attachment or accessory might be hazardous



Rotating blade hazard. Do NOT operate with guard up. Keep hands and feet away.

Figure 9 - Warning label - do not operate with guard up



Wear appropriate clothing



OPERATION

6.0 OPERATION

The **U.S.SAWS** MC-1000 saws are designed for the purpose of:

- cleaning out existing control joints
- Removing existing joint fill material
- Cutting concrete to remove deteriorated concrete for joint rebuilding

Each one of these tasks is unique in nature and require different blade configurations.

MC-1000 Blade Installation:

To install the blades on the MC-1000 remove the flanges and spacers. Install the first blade directly against the inner flange of the blade shaft assembly. Install a spacer of the desired width and then another blade and repeat the process until the desired width of cut is achieved. The MC 1000 can use one blade or up to 16 blades to achieve a maximum width of four inches. When the desired width of cut is achieved install additional spacers so that the blade nut has enough threads to tighten the assembly but not hit the inside of the blade guard. There may be leftover spacers which should be stored in a safe place for later use. The outer flange has a groove cut on the inside of it that helps keep the blades tight and also assists in loosening the blade when blade changes need to be made. It is essential that the blade nut is tight and the drive pin nut is also tight. You may need to use an alternating tightening sequence to achieve tightness in both fasteners. A common way to achieve this is to tighten the blade nut then tighten the drive pin nut and then recheck the tightness of the blade nut and finally recheck the tightness of the blade nut.

Operation:

The MC-1000 is designed to be used by one operator however it is often helpful to have a helper available to move hoses, the vacuum, and obstacles in the path of the cut.

Depth Lock:

The small crank handle at the top of the operator panel is the depth lock handle. To set depth lock lower machine so that blades just touch ground with depth control lever. Screw handle clockwise until it stops. Then every full turn left will be approximately 1/4" depth verify depth of cut.

Starting the engine:

When starting the engine the blades should be raised off the ground and all guards should be in place. Open the valve on the propane tank. Set the throttle to 1/3 to 1/2 turn the ignition key to start the engine. Allow the engine to warm up for approximately 30 seconds at half throttle. Once the engine is warm you may increase the throttle to full speed and begin your cut. If the engine is running rough it may be low on propane or may need air filter service.

Cutting/Milling:

Slowly lower the blade stack into the concrete. Do not drop it or force it. Be prepared for the machine to push back against the operator until full

Once the blades have reached full depth the operator may begin pushing the machine forwards. It is worth noting that this machine is very slow moving forward. The deeper and wider you cut the slower it will go. Use patience and allow the diamond blades to do the cutting. Excessive force will create excessive heat and damage the diamond blades. This machine is intended to be used by a fully capable adult that has both strength and equipment operation knowledge and experience.

Dust collection:

This machine must use a dust collector that has a minimum of 350 CFM. It is important to note the inside of the blade guard has a plenum type dust collection port. If dust is escaping there may be debris in the plenum. Periodically shut the saw off and check if dust is not being collected efficiently. Removal of polyurea joint fill will also cause blockage from time to time.

When overlapping cuts it may be necessary to use a smaller less powerful vacuum in addition to the main vacuum to collect dust if a portion of the blade guard is overhanging a previous cut.

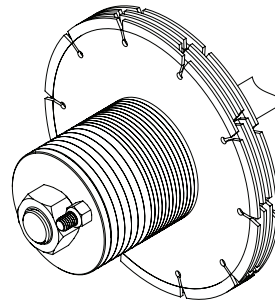

1. When clamping nut, make sure there are only two threads or less exposed at end of shaft
2. Tighten large nut first
3. Tighten 3/8" stud nut



OPERATION

- 6.1 Follow all pre-operating instructions



WARNING: Never attempt to start the engine with the diamond blade inserted in a joint or previous cut. The blade will turn as soon as the MC-1000 is started. This could damage the blade or cause the MC-1000 to jump backwards.

- 6.2 Turn on the vacuum system.
- 6.3 Move the throttle lever away from the SLOW position, about 1/3 of the way toward the fast position.
- 6.4 Turn the engine key to the ON position and allow propane and safety sensors to start (10 seconds) then start engine.
- 6.5 Once engine has warmed up increase to full throttle. Then lower machine to the lower control handle to pre-set depth.
- 6.6 Cut with the machine for a few inches. Use lift control the blades rest out of the cut then turn the machine off.
- 6.7 Measure the depth of cut and adjust as necessary.



WARNING: Do not twist the blade in the cut. Never attempt to cut any pattern or follow any joint that is not a straight line. Do not force the blade forward. These actions could damage the blade and MC-1000 unit.

- 6.8 Proceed to clean out the joint as required. Remove blade from the cut as described in 6.6.
- 6.9 In the event of an emergency related to the blade, step to the left of the machine and turn the Motor OFF if possible.



WARNING: Beware that after shutting off engine, the blade will continue spinning for several seconds. Keep a firm hold on the handle grips and maintain control of the machine until the blade completely stops.

- 6.10 For normal shut down. Pull the saw blade out of the cut by using raise control handle until the blade clear the cut. Reduce engine throttle to idle and let engine spool down and idle for 15 seconds. Then turn key to off position.
- 6.11 For any other emergency, such as fire, use the normal procedure above, 6.16, to pull the saw blade out of the cut.



PARTS BREAKDOWN

FRONT AXLE ASSEMBLY		
PART NUMBER	QUANTITY	DESCRIPTION
5100-35	1	Weldment
3002-35	2	Front Wheel - 6" x2"
2103-35	2	Collar - 1"
2104-35	2	Pillow Block Bearing - 1"
2105-35	2	Pin - 5/8" x 3.5"
HYDRAULIC RAISE/LOWER ASSEMBLY		
3100-35	1	Pump Motor
3101-35	1	Raise Flow Control Valve
3102-35	1	Hydraulic Cylinder
3103-35	1	Raise/Lower Assembly
3106-35	1	Solenoid
3015-35	1	Lowering Solenoid Valve
HYDROSTATIC DRIVE ASSEMBLY		
4100-35	1	Hydraulic Pump
4101-35	2	Wheel Motor
4103-35	2	Wheel Hub
3001-35	2	Rear Wheel - 10" x 3"
4105-35	1	Filter Assembly
4106-35	1	Filter
4107-35	1	Reservoir - Plastic
4201-35	1	Forward/Reverse Lever Assembly
4109-35	1	Drive Cable
4110-35	2	Cable End - Balljoint
4111-35	1	Hydraulic Pump Belt 4L370 or A-35
4112-35	1	Wheel Motor Bracket
4113-35	1	Hydrostatic Drive Pump Bracket
41010-35	2	Cable End - Balljoint
POINTER ASSEMBLY		
5101-35	1	3" Pointer Wheel
5102-35	2	Delrin Bushing
5103-35	2	Pointer Cable
5104-35	1	Lift Cable
5100-35	1	Weldment
FRAME CONSOLE/ ENGINE		
6100-35	1	Mainframe
6101-35	1	Console
6104-35	1	Belt Guard - Right Side Rear
6105-35	1	Rear Cover
3022-35	2	Handlebar
3026-35	2	Locking T - Handle
3031-35	1	Throttle Cable 48"



PARTS BREAKDOWN

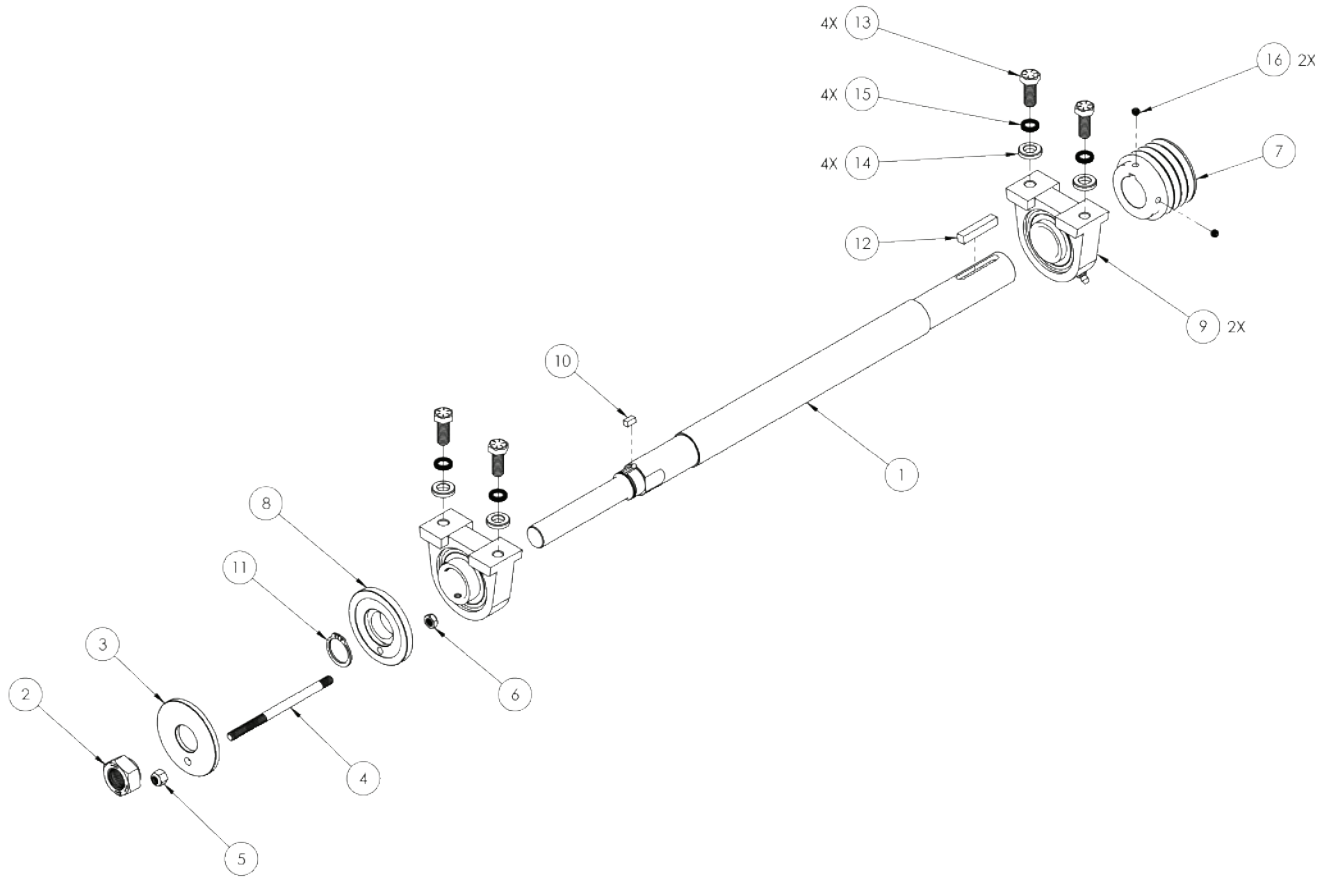

ITEM NO.	PART NUMBER	QTY	DESCRIPTION
1	SX78225	1	MC1000 BLADE SHAFT
2	SX78226	1	LH HIGH-STRENGTH STEEL HEX NUT
3	SX80512	1	JS OUTER FLANGE
4	US31172-3	1	3/8-16 STEEL STUD
5	US31052-2	1	3/8"-16 NYLON LOCK NUT, STD HEIGHT
6	US31052	1	3/8" THIN NYLON LOCK NUT
7	SX78231	1	3" OD 1-7/16 BORE 4X3VX PULLEY
8	SX78230	1	JS DRIVE FLANGE
9	US32300	2	1-7/16 PILLOW BLOCK BEARING
10	US31195	1	1/4" SQ X 1/2" MACHINE KEY
11	US32102-22	1	1-1/4" HEAVY DUTY EXTERNAL RETAINING RING
12	US31195-32	1	3/8" SQUARE X 2.0" LONG STEEL KEY
13	US31222-5	4	1/2"-13 X 1-1/4" HEX HEAD BOLT, GRADE 8
14	US31058-2	4	1/2" STEEL OVERSIZED WASHER
15	US31058-5	4	1/2" SPRING/WEDGE LOCK WASHER
16	US27539-2	2	5/16"-24 X 1/4" SET SCREW



PARTS BREAKDOWN

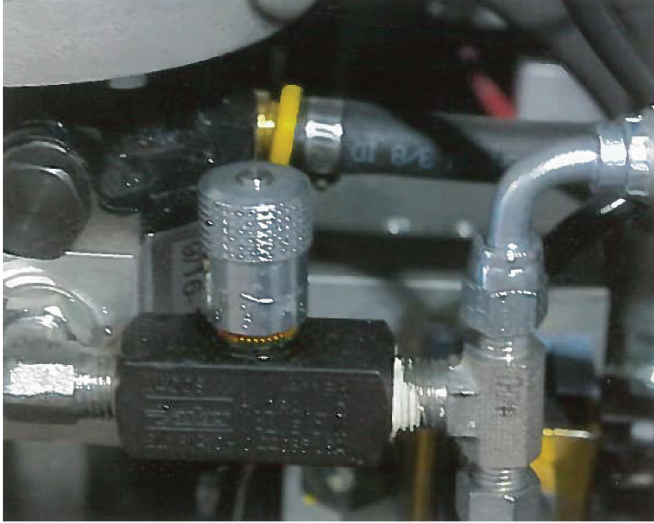

FLOW CONTROL VALVES

Inside the rear access panel on the left side is a flow control valve that allows you to adjust the raising speed.

On the righthand side below the fuel tank is a flow control valve to adjust the lowering speed.

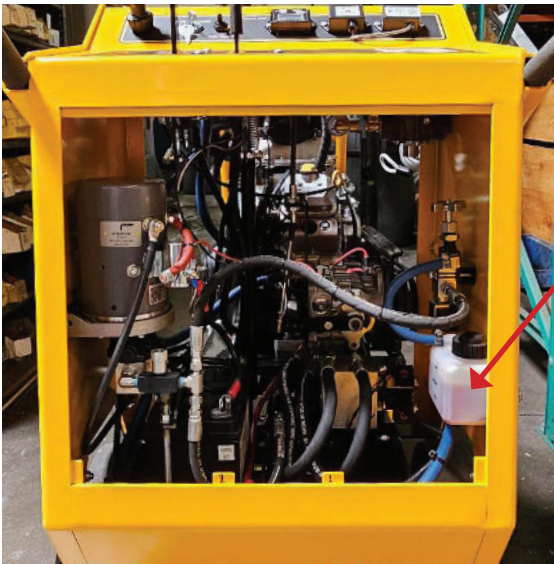

Hydraulic Raise Fluid Tank

Located underneath the right handle bar.

Use standard automatic transmission fluid.

Hydrostatic Drive Oil Tank

Located at the center right side of the machine when standing at the operating controls.

Use 20w-50 motor oil.

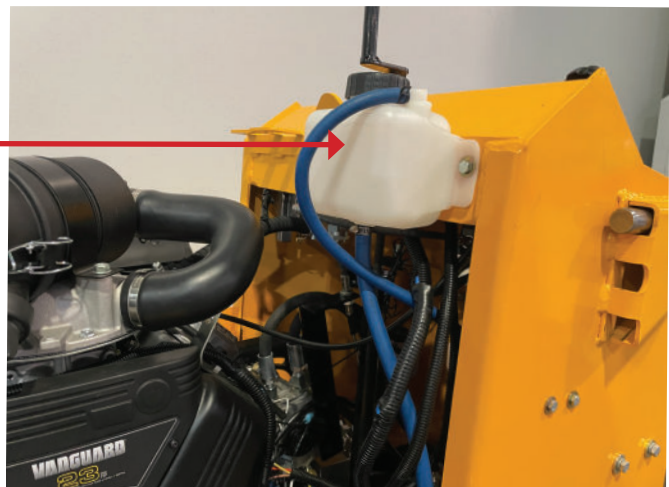

MAINTENANCE AND INSPECTION

7.0 MAINTENANCE AND INSPECTION



WARNING: The ensure key switch to the OFF position, and turn the fuel valve lever to the OFF position before performing any maintenance and inspection. This will be referred to as the MC-1000 OFF position in sections 7.1 through 7.7.



WARNING: Damaged diamond blades are hazardous and should never be used on a MC-1000. Inspect diamond blades at least twice daily and before each use for signs of damage.



TO AVOID INJURY.

Always inspect saw blades before use. Replace all cracked or damaged blades.

Figure 17 - Warning label - inspect blades before use



CAUTION: Running the MC-1000 generates heat in the engine muffler, blade and blade guard. Do not touch these components without proper heat protecting work gloves.

7.1 Removing and installing the blade

7.1.1 With engine in the OFF position, loosen the clamping knob and remove both 1-1/2" blade change wrenches from the MC-1000 handle.

7.1.2 Remove bolt in the blade guard holding bracket. Hold the blade guard firmly and raise guard up into the holding bracket. Reinsert bolt in the blade guard holding bracket and tighten nut.

7.1.3 Place one wrench on the drive flange to hold the blade shaft in place. Place the other wrench on the blade nut and turn counter-clockwise to loosen the nut.

7.1.4 Unscrew the blade nut. Slide the outer flange, spacers and blade off the shaft.

7.1.5 Replace blade, spacers, and outer flange. Outer flange pin must line up with all spacers and drive flange to fit through properly.



WARNING: Be sure that the flanges, spacers, and blade are clean and undamaged before mounting. Do not use damaged parts. The MC-1000 maximum blade operating speed is 5850 rpm as labeled on the blade guard. The MC-1000 shaft diameter is 1 inch. Therefore, only use dry cut diamond blades rated for higher than 5850 rpm maximum safe speed and designed for 1-inch diameter shafts. Using a non dry cut diamond blade or a blade rated below 5850 rpm could result in severe blade failure, personal injury or death. Never cut material for which the blade was not designed. Check blade manufacturer's guidelines on material to be cut. Never operate a blade in the wrong rotation direction. Verify blade direction when changing blades.

5850 RPM

Figure 28 - Max RPM label - maximum blade speed



2 Hazard Communication Systems, LLC
800-746-0241



Use only diamond blades (steel centered diamond cutting-off wheels) with this machine. RPM rating on blade must exceed machine max rpm rating. The use of any other blade could result in death or serious injury.

Reorder No. HSOU-369WHPL

Figure 19 - Warning label - use only diamond blades

7.1.6 Spacers can be removed to allow room for the blade thickness.

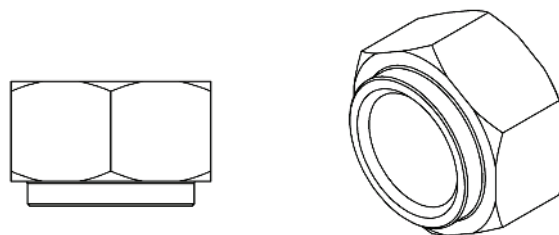

Figure 20 - Blade nut face must be flat against outer flange



MAINTENANCE AND INSPECTION

7.1.7 Screw on and tighten the blade nut with wrenches making sure the face is flat against the outer flange. The blade shaft should be flush or slightly stick out beyond the blade nut to ensure all the blade nut threads are engaged. The outer flange pin should not touch the MC-1000 chassis and 1/2" hex bolts when rotating. Rotate blade by hand to verify proper clearance and that the blade runs true (without wobbling). See Figure 30 and Figure 31. Never use a blade with interference or that does not run true.

7.1.8 Lift up on blade guard and remove bolt in blade guard holding bracket. Lower the blade guard down. Reinsert bolt and tighten nut to prevent vibration. Always run a MC-1000 with the blade guard in the down position.



WARNING: Breathable silica may be generated by use of this product; Silica can cause severe and permanent lung damage, cancer, and other serious diseases. Do not breathe the dust. Do not rely on your sight or smell to determine if the dust is in the air. Silica may be in the air without a visible dust cloud. If air monitoring equipment for silica is not provided by your employer at your work site, you **MUST** wear appropriate respiratory protection when using or servicing the machine. Consult your employer and OSHA regarding the appropriate respiratory protection.

7.2.3 With the dust brush in the desired position, tighten the 3/8-inch hex nut by turning it counterclockwise.

7.3 Checking and adjusting belt tension

7.3.1 The belt tension should be checked after the first hour of operation on a new MC-1000 or new belt. On a used MC-1000, the belt tension should be checked once a day. With engine in the OFF position, remove the four 5/16" hex bolts that attach the belt guard to the chassis.

7.3.2 Remove the belt guard. The belt should deflect no more than 1/16" under moderate finger pressure equidistant between the sheaves.

7.3.3 To tighten the belt, loosen the four 5/16" hex nuts that hold the Vanguard engine to the chassis. Then, turn the 3/8" hex head bolt clockwise on the front of the MC-1000. This bolt can be seen as item #44 in Figure 18.

7.3.4 After reaching the desired belt tension, verify that the belt sheaves are properly aligned and the belt is straight. Retighten the four 5/16" hex nuts that hold the engine against the chassis.

7.3.5 Replace the belt guard with the four 5/16" hex bolts that were removed in step 7.3.1. Never run a MC-1000 without the belt guard in place.

7.4 Bearing lubrication

7.4.1 With engine in the OFF position, slowly tilt the MC-1000 back until the handle rests on the ground.

7.4.2 These bearings are exposed to excessive dust and require the same brand of high quality grease as supplied by the factory. Apply ALVANIA® Grease 3 with a hand grease gun to both flanged bearings on the blade shaft after every 100 hours of use.

7.4.3 The performance of the bearing is greatly influenced by the quantity of grease. For optimum performance, insert grease until a little bleeds out from between the outer ring raceway and the perimeter of the slinger. Wipe off excess grease.

7.4.4 Slowly tilt the MC-1000 forward until all wheels are back on the work surface.

7.2.3 With the dust brush in the desired position, tighten the 3/8-inch hex nut by turning it counterclockwise.

7.3 Checking and adjusting belt tension

7.3.1 The belt tension should be checked after the first hour of operation on a new MC-1000 or new belt. On a used MC-1000, the belt tension should be checked once a day. With engine in the OFF position, remove the four 5/16" hex bolts that attach the belt guard to the chassis.

7.3.2 Remove the belt guard. The belt should deflect no more than 1/16" under moderate finger pressure equidistant between the sheaves.

7.3.3 To tighten the belt, loosen the four 5/16" hex nuts that hold the Vanguard engine to the chassis. Then, turn the 3/8" hex head bolt clockwise on the front of the MC-1000. This bolt can be seen as item #44 in Figure 18.

7.3.4 After reaching the desired belt tension, verify that the belt sheaves are properly aligned and the belt is straight. Retighten the four 5/16" hex nuts that hold the engine against the chassis.

7.3.5 Replace the belt guard with the four 5/16" hex bolts that were removed in step 7.3.1. Never run a MC-1000 without the belt guard in place.

7.4 Bearing lubrication

7.4.1 With engine in the OFF position, slowly tilt the MC-1000 back until the handle rests on the ground.

7.4.2 These bearings are exposed to excessive dust and require the same brand of high quality grease as supplied by the factory. Apply ALVANIA® Grease 3 with a hand grease gun to both flanged bearings on the blade shaft after every 100 hours of use.

7.4.3 The performance of the bearing is greatly influenced by the quantity of grease. For optimum performance, insert grease until a little bleeds out from between the outer ring raceway and the perimeter of the slinger. Wipe off excess grease.



PROPANE POWER SYSTEM

Figure 23- Propane wiring Diagram

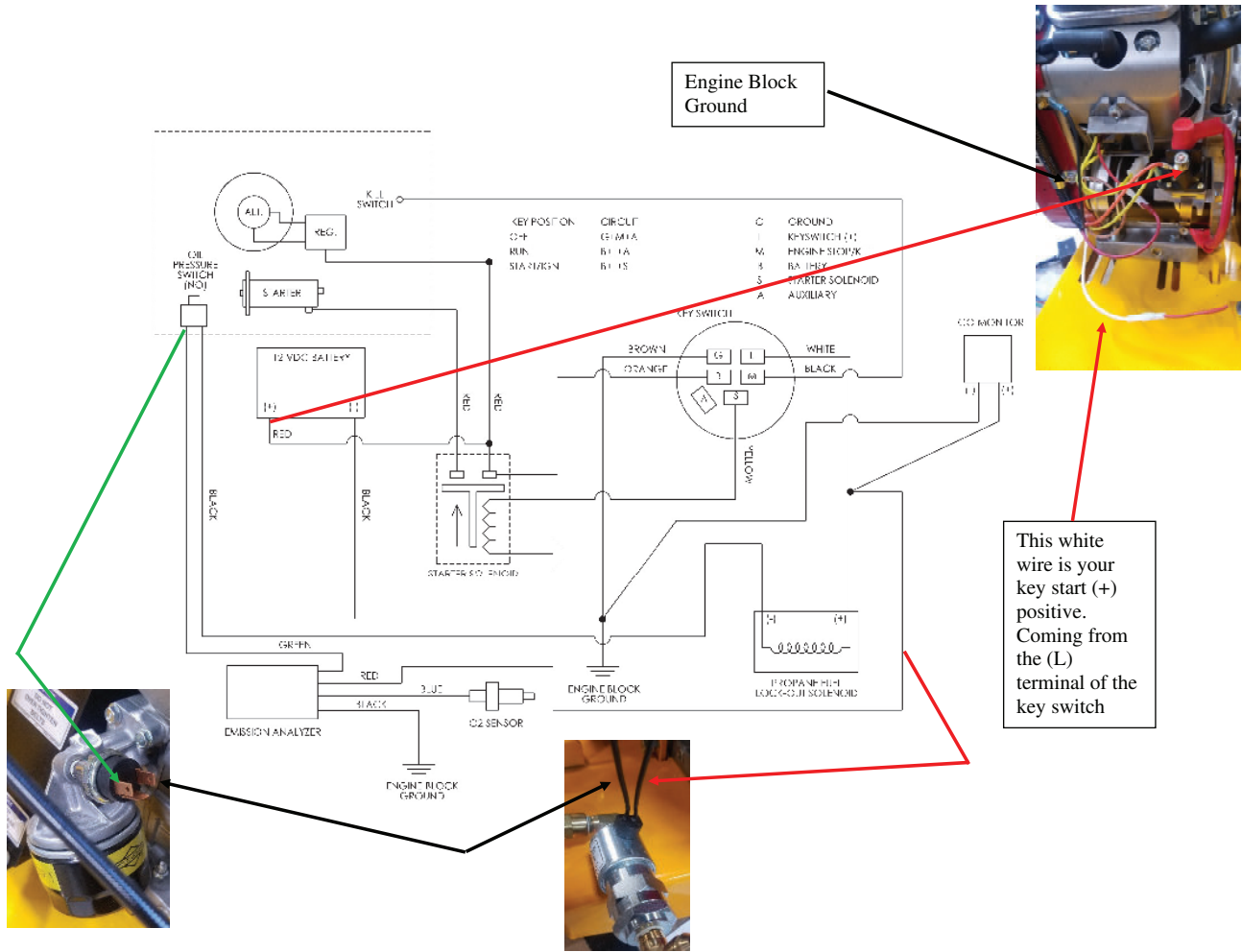

PROPANE POWER SYSTEM

8.0 Read this Operation, Safety, and Maintenance Manual carefully. Be familiar with the controls and the proper use of the equipment.

8.1 PREPARATION – BEFORE EACH USE:

- Do not operate and or store equipment or replacement cylinder(s) near sources of heat, open flames or sources of ignition, including cigarettes.
- Check for fuel leaks prior to operating the store equipment, utilizing leak detecting soap.
- Propane-Gas Cylinder and fuel system are under pressure. Avoid damage to these components that could result in fuel leaks.
- Close fuel cylinder service valve(s) when the equipment is not in use or when transporting the equipment.
- Do not operate or store equipment in an unventilated area.
- This equipment has been converted to operate on Propane-Gas fuel and may perform or handle differently than as originally manufactured.
- For additional information, read and follow all on-product warning labels provided by Propane Power Systems and your Propane-Gas supplier.
- Replace faulty mufflers

8.2 OPERATION:

- Never operate the machine with defective guards or shields, or without safety protective devices in place.

8.3 INSTRUCTION & SAFETY DECALS:

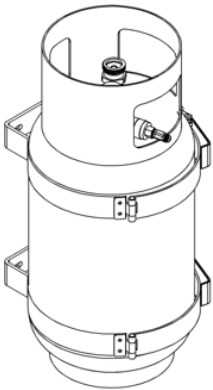

The fuel conversion for the Briggs & Stratton 627cc-Propane Powered System engine must use special vapor tanks that are specifically designed for vapor run small engine applications for concrete equipment. These tanks are available thru your local propane distributor/company or PPS.

RPS150034



1. Propane Tank Specification
2. Use Propane Powered Systems Approved Tank Only
3. Mounting: Vertical
4. Quick Disconnect Valve: RH ACME Thread
5. Capacity: **33.5 LB -ONLY FILL TO 80% (26.8 LB)-**
6. Fuel Withdraw: Vapor

RPS150035

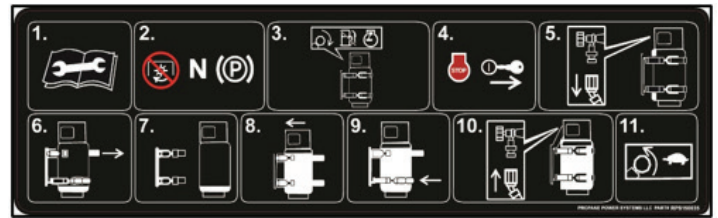

1. Familiarize yourself with the instructions listed below.
2. Stop the equipment on a flat surface, do not turn off engine, place transmission into neutral and engage the parking break.
3. Close the fuel valve on the propane tank by rotating clockwise; continue to run the engine.
4. When the engine shuts off, from the lack of propane fuel, turn the key to the off position and then remove the key.
5. Disconnect the ACME right hand thread connector from the propane tank.
6. Unlatch the two tank traps from the propane tank.
7. Remove the empty propane tank and inspect tank. Make sure both the fill valve and service valve are clean of debris.
8. Install the filled propane tank.
9. Latch the two tank straps onto the propane tank; make sure the propane tank is securely fastened to the tank straps.
10. Reconnect the ACME right hand thread connector to the service valve on the propane tank.
11. Slowly open the propane service valve counter-clockwise to equalize the pressure, check for leaks.



PROPANE POWER SYSTEM

RPS150036



1. Danger – Propane fuel is extremely flammable and vapors are explosive.
2. Read the Operator's Manual. See NFPA 58: Liquefied Petroleum Gas Code for additional safety information.
3. Do not smoke or replace the tank around any sources of ignition.
4. Do not attempt or modify the tank or its components. Use only propane tanks approved by Propane Power Systems, LLC.
5. Close the fuel valve when the equipment is not in use, in storage or transporting.
6. Avoid contact with the propane fuel. Escaping vapors and liquids freeze skin on contact.

8.4 BEFORE OPERATION SAFETY

FUEL SAFETY

- Propane tanks should be filled by trained and qualified personnel only.
- Do not change the tank when the engine is running.
- Never tamper with or repair tanks; contact trained and qualified personnel only.
- Before disconnecting the fuel hose, close the fuel valve on the tank and allow the engine to run until it stops to purge all of the propane vapors from the system.
- Do not operate the machine without the entire exhaust system in place and in proper working condition.
- Propane is heavier than air and may accumulate in low lying areas.
- To avoid personal injury or property damage, use extreme care in handling propane fuel. Fuel vapors are flammable and explosive.
- Never smoke around propane fuel tanks and stay away from an open flame or where fumes may be ignited by a spark.
- Extinguish all sources of spark or flame when approaching propane tanks or the equipment.
- Store the tank(s) away from heat, sparks or open flames.

TYPE OF FUEL: HD5 GRADE PROPANE



Caution – Using overfilled tanks will result in damage to the fuel system regulator.

NEVER USE PROPANE TANKS THAT ARE FILLED BEYOND 80% CAPACITY



Propane Service Valve on Vapor Port

Fill Valve on Liquid Port

FILLING PROPANE TANKS



Danger – Use extreme caution when handling propane. Propane is flammable and explosive and can cause personal injury if not handled properly.

No smoking or open flame around propane.

Fill the propane tank outdoors in a well-ventilated area.

Storage locations and trailers should be equipped with at least 1 approved portable fire extinguisher that has a minimum capacity of 18 lbs dry chemical with a B:C rating. Do not use carbon-tetrachloride extinguishers such as Pyrene.

- The propane tank must be removed from the equipment for filling.
- Only use propane when operating this machine. Never use any other type of fuel including diesel or methanol as serious damage in the engine will occur.
- The Briggs & Stratton 570cc Propane Power System engine must use special vapor tanks that are specifically designed for vapor run small engine applications.
- Turn off the service valve, unscrew the ACME left hand thread connector and unlatch the propane tank straps.
- Remove the tank from the equipment.
- The tank must be filled by a trained propane filling station attendant or have been officially trained by a propane fuel provider.
- The propane information in this Operator's Manual is provided only as a guide. Consult the NFPA 58: Liquefied Petroleum Gas Code, 2008 Edition for additional safety information. The National Fire Protection Association (NFPA) code pertain to the handling, storing, transporting and usage of propane fuel.



PROPANE POWER SYSTEM

8.4 Operational Set Up

Engine Oil Level & Adding Oil

Oil Capacity = 46 – 48 fl oz

- The engine(s) are tested and set at the factory. Then the oil is drained for shipment.

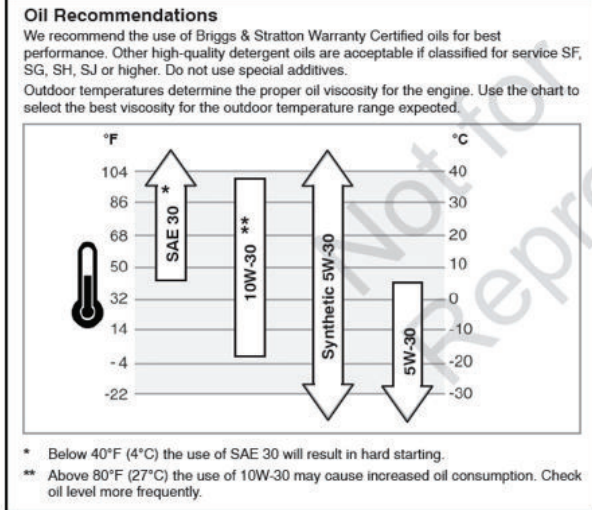

Figure - 1

- PPS recommends the use of Synthetic 5W-30. Better for engine brake in period and longer duration between oil changes

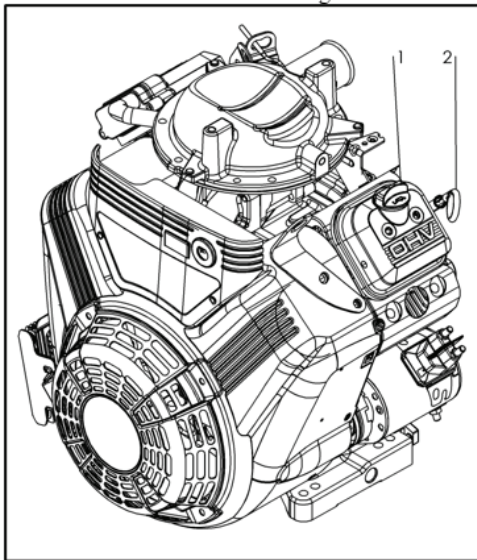

Figure - 2

- Remove the (1) filler cap and slowly add approximately 80% of the specified oil and slowly add the additional oil to bring the level of oil to the full mark on the (2) dipstick (Figure-2).

Familiarization of Vertical Propane Vapor Tank

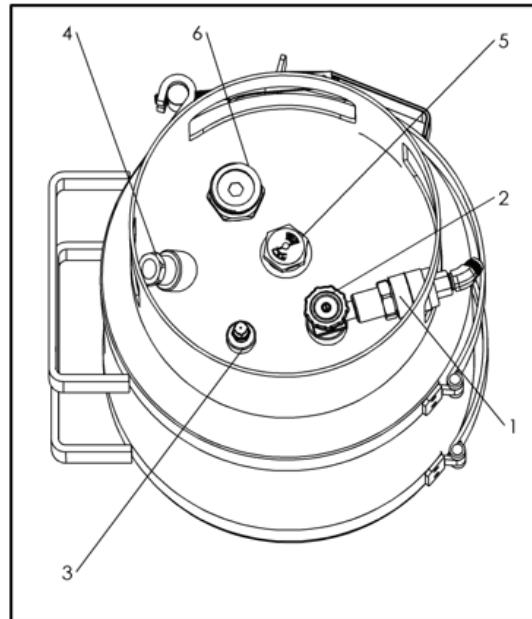

Figure - 3

- The equipment operators need to familiarize themselves with the connections, valves and gauges on the propane tanks.
- Figure -3 identifies the connections, valves and gauges as the following:
 - Quick Disconnect Right Hand ACME Thread Valve.
 - Vapor Tank Service Valve.
 - Bleeder Valve (Only to be used by trained and qualified personnel. The bleeder valve is used during the propane fill process).
 - Safety – Pressure Relief Valve
 - Propane – Fuel Gauge
 - Fill Valve (Only to be used by trained and qualified personnel).



WARRANTY AND SERVICE

8.0 WARRANTY AND SERVICE

8.1.1 Warranty

This document is to be used as a guide in determining warranty policies and procedures for U.S.SAWS and its U.S.SAWS products. It is to be used in determining whether a warranty is justified and as a procedural guide in completing a U.S.SAWS warranty claim form.

8.1.2 Warranty Responsibility

The distributor or the end user must prepare a Machine Warranty Information Card when the machine is delivered. Failure to comply will make any and all warranties on this equipment null and void. Credit for warranty repairs will be given only after receipt of the WARRANTY CLAIM FORM, properly completed with all the required details. Submittal details are described later in this document.

8.1.3 Warranty Policy

8.1.3.1 U.S.SAWS warrants its U.S.SAWS products against defects in material and workmanship under normal and proper use for a period of one year (365) days from the date of delivery; in the case of Rental Fleet Machines, date of assignment to Rental Fleet. Such warranty is extended only to the buyer who purchases the equipment directly from U.S.SAWS or its authorized distributor. This warranty does not include expendable parts such as, but not limited to, plugs, cutters, blades, blast wheel, wear parts, liners and seals.

8.1.3.2 The obligation under this warranty is strictly limited to the replacement or repair, at US SAWS's option, of machines and does not include the cost of transportation, loss of operating time, or normal maintenance services.

8.1.3.3 This warranty does not apply to failure occurring as a result of abuse, misuse, negligence, corrosion, erosion, normal wear and tear, alterations or modifications made to the machine without express written consent of U.S.SAWS .

8.1.3.4 Warranty request must be submitted in writing within thirty (30) days after failure.

8.1.3.5 Written authorization to return merchandise under warranty must first be obtained from U.S.SAWS .

8.1.3.6 U.S.SAWS reserves the right to inspect and make the final decision on any merchandise returned under warranty.

8.1.3.7 U.S.SAWS offers no warranty with respect to accessories, including but not limited to, engines, motors, batteries, electrical boards, tires and any other parts not manufactured by us but which the original manufacturer warrants.

8.1.3.8 U.S.SAWS reserves the right to make product changes or improvements without prior notice and without imposing any obligation upon itself to install the same on its products previously sold.

8.1.3.9 The above warranty conditions can only be altered by U.S.SAWS. U.S.SAWS must confirm alterations in writing for each specific transaction.

8.1.3.10 U.S.SAWS reserves the right to establish specific warranty terms for used or demo machines on an individual transaction basis. Invoices covering such merchandise will clearly state the provisions of the applicable warranty for each specific transaction.

8.1.3.11 WE DO NOT AUTHORIZE ANY PERSON, REPRESENTATIVE OR SERVICE OR SALES ORGANIZATION TO MAKE ANY OTHER WARRANTY OR TO ASSUME FOR US ANY LIABILITY IN CONNECTION WITH THE SALE OF OUR PRODUCTS OTHER THAN THOSE CONTAINED HEREIN.

8.1.3.12 UNDER NO CIRCUMSTANCES SHALL US SAWS BE LIABLE TO CUSTOMER OR ANY OTHER PERSON FOR ANY DIRECT, INCIDENTAL, OR CONSEQUENTIAL DAMAGES RESULTING FROM THE USE OF THE PRODUCT OR ARISING OUT OF ANY BREACH OF ANY WARRANTY OR FOR ANY SPECIAL OR CONSEQUENTIAL DAMAGES OF ANY CHARACTER, INCLUDING WITHOUT LIMITATIONS, DAMAGES FOR ANY LOSS OF GOODWILL, WORK STOPPAGE, OR ANY AND ALL OTHER COMMERCIAL DAMAGES OR LOSSES.

8.1.3.13 U.S.SAWS MAKES NO OTHER WARRANTIES, EXPRESSED OR IMPLIED, INCLUDING, BUT NOT LIMITED TO, THE IMPLIED WARRANTIES OF MERCHANTABILITY AND FITNESS FOR A PARTICULAR PURPOSE WITH RESPECT TO THE US SAWS PRODUCTS SOLD PURSUANT THERETO.



MACHINE WARRANTY INFORMATION CARD

TO ENSURE THE PROPER WARRANTY COVERAGE IS EXTENDED TO THE OWNER OF THIS MACHINE, FILL OUT THE ATTACHED CARD COMPLETELY AND ACCURATELY.

WARRANTY REGISTRATION CARD

IMPORTANT! To ensure that your U.S.SAWS machine is covered under warranty, please fill in the following information and mail or fax it to U.S.SAWS, 8004B E. Broadway Ave. Tampa, FL 33619 Fax No. (813) 621-7125.

COMPANY
NAME
ADDRESS
INTENDED USE
DATE OF PURCHASE
INTENDED USE
SERIAL NUMBER

If you are not the owner of record as shown on the manual copy of the warranty registration card, do not operate this machine before contacting U.S.SAWS at 1-877-817-6687. Verify the following before operating the equipment:

CHANGE OF OWNER OR NEW ADDRESS REGISTRATION CARD

IMPORTANT! To ensure that your U.S.SAWS machine is covered under warranty, please fill in the following information and mail or fax it to U.S. SAWS, 8004B E. Broadway Ave. Tampa, FL 33619, Fax No. (813) 621-7125.

COMPANY
NAME
ADDRESS
INTENDED USE
DATE OF PURCHASE
INTENDED USE
SERIAL NUMBER

18



**SURFACE PREP
DIVISION**

P: 877-817- 6687
Visit us at www.ussaws.com
sales@ussaws.com

